



DIGITAL BUILDING COMPONENTS

624 North 44th Avenue

Phoenix, AZ 85043

(602) 283-4462

www.digitalbuilding.com

COLD-FORMED STEEL FRAMING MEMBERS AND PANELS

CSI Section:

- 05 10 00 Structural Metal Framing
- 05 12 00 Structural Steel Framing
- 05 31 00 Steel Decking
- 05 40 00 Cold-Formed Metal Framing
- 05 41 00 Structural Metal Stud Framing
- 05 42 00 Cold-Formed Metal Joist Framing
- 05 44 00 Cold-Formed Metal Trusses
- 06 16 00 Sheathing
- 06 16 13 Insulating Sheathing
- 06 16 33 Wood Board Sheathing
- 06 16 43 Gypsum Sheathing
- 06 16 53 Moisture-Resistant Sheathing Board
- 06 16 63 Cementitious Sheathing
- 07 25 00 Water-Resistive Barriers/Weather Barriers
- 07 27 00 Air Barriers
- 09 22 00 Supports for Plaster and Gypsum Board
- 09 22 16 Non-Structural Metal Framing

1.0 RECOGNITION

Digital Building Components steel framing members recognized in this report have been evaluated for use as light-frame construction elements. The structural performance and fire resistance properties of the steel framing members comply with the intent of the provisions of the following codes and regulations:

- 2021, 2018, 2015, and 2012 International Building Code® (IBC)
- 2021, 2018, 2015, and 2012 International Residential Code® (IRC)

2.0 LIMITATIONS

Use of the Digital Building Components steel framing members recognized in this report is subject to the following limitations:

2.1 Digital Building Components framing members shall be installed and identified in accordance with this report, codes listed in Section 1.0 of this report, and the manufacturer's instructions. Where conflicts occur, the more restrictive shall govern.

2.2 Members shall be designed by a registered design professional with structural properties determined in accordance with Section 3.2 of this report.

2.3 Plans, calculations, and specifications verifying compliance with the applicable building code and this report shall be submitted to the building official for approval. The documents shall be prepared and sealed by a registered design professional where required by the statutes of the jurisdiction in which the project is to be constructed.

2.4 The minimum uncoated steel thickness of cold-formed members, as delivered to the job site, shall be at least 95 percent of the designed base steel thickness as specified in [Table 1](#) of this report.

2.5 A minimum zinc coating of G60 or equivalent is required for all applications.

2.6 Framing members and panelized assemblies are produced in manufacturing facilities in Phoenix, Arizona.

3.0 PRODUCT USE

3.1 General: Digital Building Components steel framing members are used for interior and exterior load-bearing and non-load-bearing wall framing and floor or roof framing in compliance with Sections 2210, 2211, or 2508 of the IBC. The framing members are also alternatives to framing complying with Sections R505, R603, and R804 of the IRC where an engineered design is performed in accordance with IRC Section R301.1.3. Digital Building Components Panelized Wall Systems and Digital Building Components Panelized Floor/Roof Systems are assembled from the framing members and comply as prefabricated construction in accordance with IBC Appendix K, Section K107.

3.2 Design:

3.2.1 Structural Framing: Structural properties for the Digital Building Component stud and track framing members shall be determined in accordance with the AISI code referenced from Sections 2210 or 2211 of the IBC. Use the dimensions provided in Table 2 and Table 3 of this report for the analysis. The web crippling capacity of the flexural members shall be calculated in accordance with Section G5 of AISI S100-16 (2020) w/S2-20 and AISI S100-16 or Section C3.4 of AISI S100-12 and AISI S100-07/S2-10 using the flat web height (h) provided in [Table 2](#) and [Table 3](#) of this report. The design of flexural members shall also address combined bending and web crippling as well as, combined bending and shear, as applicable. The design of compression members shall address axial tension or compression stresses alone and combined axial and bending stresses, as applicable.

3.2.2 IRC: The information in this report is permitted under the IRC where an engineered design is provided, in accordance with IRC Section R301.1.3.

The product described in this Uniform Evaluation Service (UES) Report has been evaluated as an alternative material, design or method of construction in order to satisfy and comply with the intent of the provision of the code, as noted in this report, and for at least equivalence to that prescribed in the code in quality, strength, effectiveness, fire resistance, durability and safety, as applicable, in accordance with IBC Section 104.11. This document shall only be reproduced in its entirety.





3.2.3 Nonstructural Framing: For the purpose of this report, members that are to be designed as nonstructural shall comply with Chapter 22 of the IBC and the limitations of Section A1 of AISI S220 (2021, 2018, and 2015 IBC) or Section A2 of AISI S200 (2012 IBC). If a member is deemed to be nonstructural according to AISI S200 or AISI S220, the registered design professional may use the safety factor or resistance factor specified in Section B1 of AISI S220.

3.2.4 Accessories: All structural components such as connection plates and gussets, shall be designed in accordance with the applicable code by the registered design professional, fabricated in compliance with IAPMO Uniform ES EC-020, and approved by the building official.

3.2.5 Members with Holes:

3.2.5.1 Members with Standard Holes: For members with standard holes (punch-outs) the applicable provisions of AISI S100 shall be used to determine the member properties and strength. [Figure 2](#) of this report illustrates the standard hole (punch-out) sizes available in Digital Building Components stud and track profiles.

3.2.5.2 Members with Non-Standard Holes: Digital Building Components fabricates tracks with larger non-standard holes (punch-outs) as shown in [Figure 3](#) of this report. These tracks are not intended to be used as members that span between supports but as members that are part of a Digital Building Components framing assembly. If tracks with non-standard holes are to be used as members spanning between supports, then rational engineering analysis in accordance with Section A1.2(c) of AISI S100 shall be used to determine the member properties and strengths as these holes do not meet the prescribed provisions of AISI S100. In addition, the safety and resistance factors specified for members in Section A1.2(c) of AISI S100 shall be used in the rational engineering analysis.

3.3 Installation:

3.3.1 General: Installation shall comply with this report, the approved construction documents, the manufacturer's instructions, and applicable provisions of the IBC and IRC, including Section 2210 or 2211 of the IBC, ASTM C754, and ASTM C1007.

3.3.2 Prefabricated Panelized Assemblies:

3.3.2.1 General: Digital Building Components framing member systems, described in this report are available as prefabricated non-load-bearing and load-bearing wall panel assemblies and/or floor or roof panel assemblies. These assemblies shall be constructed in accordance with requirements set forth in the approved plans and specifications and shall comply with applicable provisions in IBC Appendix K, Section K107. These assemblies may include rough-in electrical, as set forth in Section 3.3.2.4 of

this report. Since factory inspections are provided, special inspections are not required unless specified on the approved plans and specifications or required by the building official.

3.3.2.2 Welding:

- a. Tack welds are welds made to hold parts of the weldment in proper alignment until the final welds are made as defined in AWS A3.0. Tack welds specified in the construction documents by the registered design professional shall be inspected unless the inspection is waived in the construction documents. Tack welds not specified in the construction documents may be considered non-structural and are not required to be inspected.
- b. The registered design professional shall provide a statement of special inspection complying with IBC Sections 1704 and 1705 for all welding (Shop and or Field) including frequencies.
- c. Inspections: Welding inspections on metal roof and floor decks shall comply with Section 1705.2.2 of the 2021, 2018, and 2015 IBC, or Section 1705.2.2.1.1 of the 2012 IBC.
- d. Procedures and Qualifications: All welding procedures shall comply with AWS D1.1 or D1.3 and shall be reviewed and approved by a Third-Party Inspection Agency including all Robotic welding procedures.
- e. All welding personnel shall be tested by a certified welding inspector (CWI) and reviewed by a Third-Party Inspection Agency, as applicable.
- f. All structural welding processes completed mechanically by hand methods or automatically by robotic methods shall conform to the AWS D1.1 or D1.3 and be reviewed by the in-house CWI and Third-Party Inspection Agency as applicable.
- g. Unless otherwise stated in this report, Digital Building Components facilities located in Phoenix, Arizona, are in compliance with IBC Section 1704.2.5.1 and IAPMO Uniform ES EC-020 as an approved fabricator. These locations are subject to unannounced compliance audits by a Third-Party Inspection Agency.

3.3.2.3 Screw Fastening:

- a. All structural fastener types used for permanent construction shall be approved by the registered design professional.
- b. All fasteners for permanent construction shall comply with an evaluation report issued by an approved evaluation agency or conform to ASTM C1513. Alternatively, test data and structural calculations complying with AISI S100 may be submitted to the building official for approval.

3.3.2.4 Electrical: Electrical will consist of in-wall rough-in of cable and/or raceway to wiring devices (receptacles, switches, etc.) for power, audiovisual, security,



communications, etc. All electrical installation, including grounding and bonding, will be in accordance with ANSI/NFPA 70, “National Electrical Code”.

3.3.2.5 Plumbing: Plumbing will consist of rough-in of drainage, water supply, gas piping, vent piping, and all necessary fixture supports. All plumbing installations will be in accordance with the Uniform Plumbing Code (UPC) or the International Plumbing Code (IPC). The rough-in does not include sinks, faucets, or other fixtures and end elements.

3.4 Fire-Resistance-Rated Assemblies: Digital Building Components framing may be used in fire-resistance-rated construction where permitted by Section 721 of the IBC, including generic (not labeled proprietary) ratings in GA 600, and the approved construction documents.

3.5 Inspection: All panelized members and their attachments (welds or screws) shall be periodically inspected in the approved fabrication facility. Once the panel leaves the fabrication shop additional inspections of the members and connections are no longer required, except as needed for erection and connection to the supporting elements. When multiple layers of sheathing are applied in the fabrication shop each layer shall be inspected for compliance with the applicable code, GA 600 rating, or approved construction documents. Sheathing attachment inspected in the fabrication shop shall supplant inspections required in the field.

4.0 PRODUCT DESCRIPTION

4.1 Stud and Track Product Information: Digital Building Components framing members are limited to those profiles noted in [Table 2](#) and [Table 3](#) of this report. Digital Building Components studs are “C” shaped steel framing members with straight flanges and stiffeners, and straight webs with optional punch-outs. Digital Building Components tracks are “U” shaped steel framing members with straight flanges and no stiffeners, and straight webs with optional punch-outs. [Figure 1](#) of this report illustrates Digital Building Components stud and track Section Profiles. [Figure 2](#) and [Figure 3](#) of this report illustrate punch-out sizes in the studs and tracks.

4.2 Material Information: All Digital Building Components steel framing members are cold-formed from steel coils conforming to ASTM A653 or ASTM A1003. Digital Building Components studs and tracks, with a designated thickness of 54 and 68 Mils, are formed from ASTM A653 SS Grade 50 Class 1 or ASTM A1003 Structural Grade 50 Type H (ST50H). Digital Building Components studs and tracks with a designated thickness of 33 and 43 Mils are formed from ASTM A653 SS Grade 33 or ASTM A1003 Structural Grade 33 (ST33H).

4.3 Panelization Information: Digital Building Components stud and track members described in this report in [Table 2](#) and [Table 3](#) of this report are utilized in the shop manufacturing of prefabricated panelized wall systems and panelized floor or roof systems. These panelized walls, floors, and roofs are erected at the job site to form completed interior and exterior structural wall and structural floor or roof systems for single and multi-story buildings. The panels are also used for interior and exterior non-load-bearing wall systems.

4.3.1 Panelization Framing Members: In addition to the Digital Building Components stud and track members the panels may include other cold-formed steel framing members. These cold-formed steel framing members are outside the scope of this report. Documentation shall be provided to the building official demonstrating the cold-formed steel framing members comply with AISI S220 or S240, or IRC Sections R505, R603, or R804 for approval. The panels may also include structural steel or other framing members conforming to a current ASTM specification.

4.3.2 Panelization Sheathing: Panelized wall systems and panelized floor or roof systems may or may not have sheathing materials installed on the panels. The sheathing material may consist of gypsum sheathing, sheet steel, plywood, metal decking, and other materials approved and installed under the IBC.

4.3.3 Panelization Air/Water/Vapor-Resistive Barrier: Panelized wall systems and panelized floor or roof systems may or may not have an air-, water-, or vapor-resistive barrier installed on the panels. The resistive barriers shall comply with Sections 1202, 1403, 1404, 1506, or 2510 of the 2021 and 2018 IBC, Sections 1203, 1404, 1405, 1506, or 2510 of the 2015, or 2012 IBC; or IRC Sections R408, R702, R703, R806, R905 or N1102. Installation of the resistive barrier shall be in accordance with the manufacturer's recommendations.

4.3.4 Panelization Finish System: Panelized wall systems and panelized floor or roof systems may or may not have a finish system installed on the panels. The finish system shall meet the applicable requirements of Chapter 14 of the IBC for walls and Chapter 15 of the IBC for roofs, Chapter 7 of the IRC for walls, and Chapter 9 of the IRC for roofs. Installation of the finish system shall be in accordance with the manufacturer's recommendations and architectural/structural requirements specified in the contract documents.

4.3.5 Panelization with Windows: Panelized wall systems may or may not have windows installed on the panels. The windows and their attachments shall comply with Sections 1404 and 1709 (2021 and 2018 IBC) or Sections 1405 and 1709 (2015, and 2012, IBC); or Section R609 of the IRC.



4.3.6 Sealants: Sealants shall comply with ASTM C920 and be of the type, grade, class, and use classifications required to seal joints and remain weather tight. Refer to finish system manufacturer's recommendations for required sealant type.

5.0 IDENTIFICATION

Framing members shall be identified using a designator system in accordance with AISI S240 (2021, 2018 IBC) or AISI S200 (2015, 2012 IBC).

Each Digital Building Components framing member is identified with a label, stamp, or embossment, at a maximum of 96 inches (2438 mm) on center, indicating the manufacturer's name or initials ("Digital Building Components" or "DBC"), the product name, the minimum base steel thickness, the minimum yield strength, the protective coating designation, the inspection agency designation (SEL AA-554) and the IAPMO UES Report Number (IAPMO UES-451). In addition, identification of the Digital Building Components framing members shall comply with one of the following:

1. The members are in a panel assembly that is identified as indicated in the paragraph below, or
2. The members are part of a bundle that is identified with the manufacturer's name ("Digital Building Components"), the IAPMO UES Report Number (IAPMO UES-451), and the UES Mark of Conformity, or
3. The UES Mark of Conformity is placed in one location on each individual member itself.

Each Digital Building Components wall panel assembly and floor/roof panel assembly is identified with a project-specific panel number which will correspond to the Digital Building Component layout plan that defines the panel's location within the building footprint. In addition, the panel will also be labeled indicating the manufacture's name ("Digital Building Components"), the inspection agency designation (SEL AA-554), the UES Mark of Conformity, and the IAPMO UES Report Number ("IAPMO UES ER-451").

Either UES Mark of Conformity may be used as shown below:

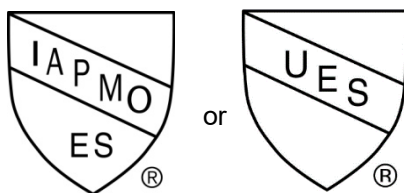

IAPMO UES ER-451

6.0 SUBSTANTIATING DATA

Data in accordance with:

- The ICC-ES Acceptance Criteria for Cold-Formed Steel Framing Members (AC46).
- UES EC-020-2020, Evaluation Criteria for Structural Steel Approved Fabricator Inspection Program, revised January 2020.
- Test reports are from laboratories in compliance with ISO/IEC 17025.

7.0 STATEMENT OF RECOGNITION

This evaluation report describes the results of research completed by IAPMO Uniform Evaluation Service on Digital Building Components steel framing members and panels to assess conformance to the codes shown in Section 1.0 of this report and serves as documentation of the product certification. Products are manufactured at locations noted in Section 2.6 of this report under a quality control program with periodic inspection under the supervision of IAPMO UES.

For additional information about this evaluation report please visit www.uniform-es.org or email us at info@uniform-es.org

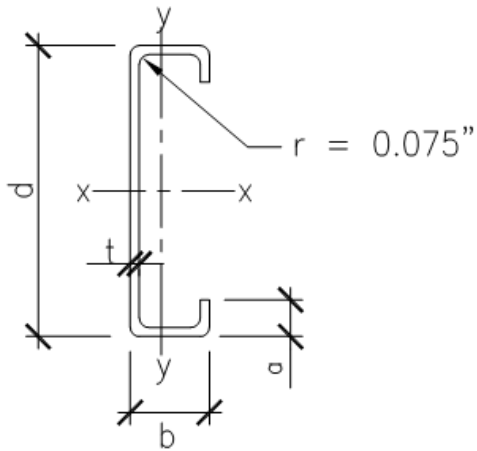

$d = 2 \frac{1}{2}"$, $3 \frac{5}{8}"$, $4"$, $6"$, $8"$, $10"$, $12"$

$b = 1 \frac{5}{8}"$, $2"$, $2 \frac{1}{2}"$

$t = 33, 43, 54, 68$ Mils

$a = \frac{1}{2}"$ when $b = 1 \frac{5}{8}"$
 $\frac{5}{8}"$ when $b = 2"$ & $2 \frac{1}{2}"$

STUDS

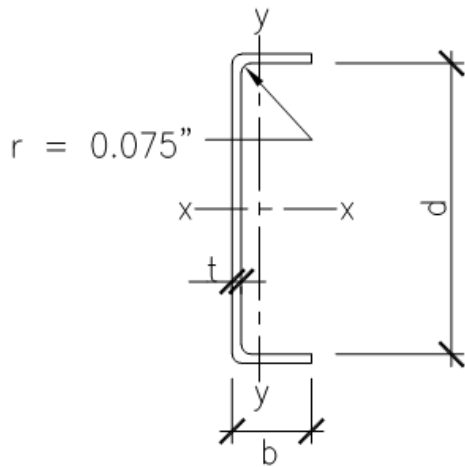

$d = 2 \frac{1}{2}"$, $3 \frac{5}{8}"$, $3 \frac{25}{32}"$, $4"$, $4 \frac{5}{32}"$,
 $6"$, $6 \frac{5}{32}"$, $8"$, $8 \frac{5}{32}"$, $10"$, $12"$

$b = 1 \frac{1}{2}"$, $2"$, $2 \frac{1}{2}"$, $3"$

$t = 33, 43, 54, 68$ Mils

TRACKS

FIGURE 1 – STUD AND TRACK SECTION PROFILES

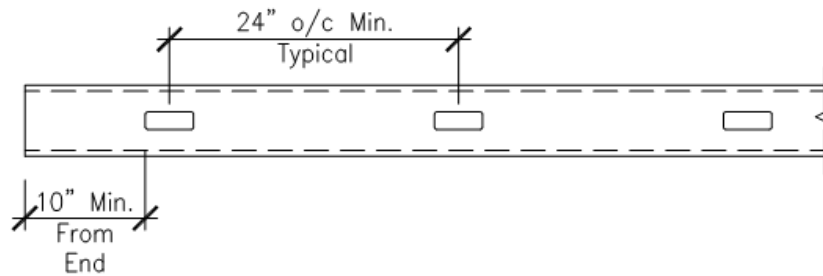

Possible Punch-out Locations Along The Stud

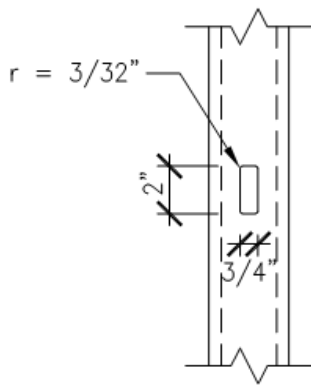

2 1/2"
Studs or Tracks

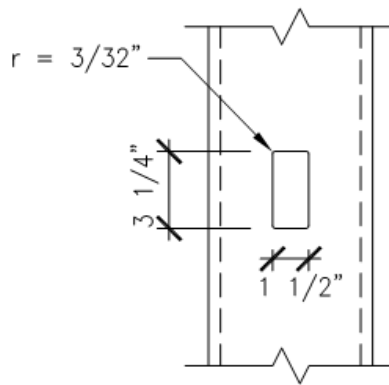

3 5/8" to 12"
Studs or Tracks

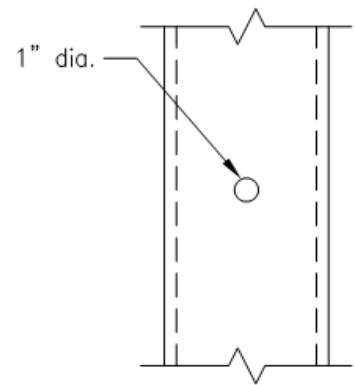

2 1/2" to 12"
Studs or Tracks

Note: All punches shall be centered in the web of the stud.

FIGURE 2 – STANDARD STUD AND TRACK PUNCH-OUTS

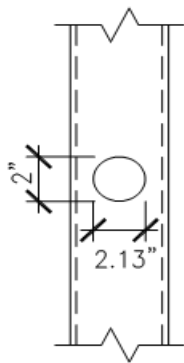

3 5/8" and 4" Tracks

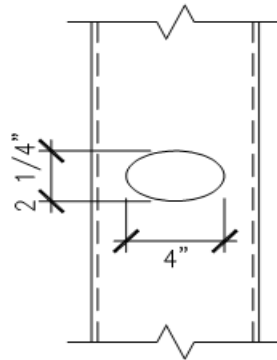

6" Tracks

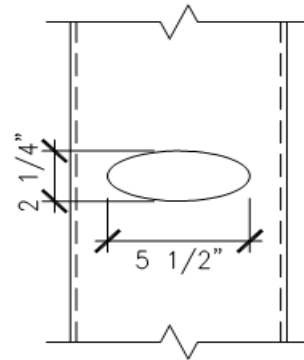

8", 10", and 12" Tracks

Note: All punches shall be centered in the web of the stud.

FIGURE 3 – LARGE NON-STANDARD TRACK PUNCH-OUTS

TABLE 1 -- DIGITAL BUILDING COMPONENTS UNCOATED STEEL THICKNESS SUMMARY

Designation Thickness (Mil)	Designation Thickness (Ga)	Design Thickness (in.)	Minimum Thickness ¹ (in.)	Inside Bend Radii (in.)	F _y (ksi)
33	20	0.0346	0.0329	0.075	33
43	18	0.0451	0.0428	0.075	33
54	16	0.0566	0.0538	0.075	50
68	14	0.0713	0.0677	0.075	50

¹ Minimum thickness represents 95 percent of the design thickness and is the minimum acceptable thickness delivered to the job site.



TABLE 2 -- DIGITAL BUILDING COMPONENTS STUD PROFILE SUMMARY ^{1,3}

Product Designation	Mils	Design Thickness (in)	F _y (ksi)	Web Depth ² (in.)	Flange Width (in.)	Lip Size (in.)	Area (in ²)	Weight (lb/ft)	Flat Web Height ⁴ (in)
250S162-33	33	0.0346	33	2.500	1.625	0.500	0.223	0.76	2.281
250S162-43	43	0.0451	33	2.500	1.625	0.500	0.289	0.98	2.260
250S162-54	54	0.0566	50	2.500	1.625	0.500	0.359	1.22	2.237
250S162-68	68	0.0713	50	2.500	1.625	0.500	0.447	1.52	2.207
250S200-33	33	0.0346	33	2.500	2.000	0.500	0.258	0.88	2.281
250S200-43	43	0.0451	33	2.500	2.000	0.500	0.334	1.14	2.260
250S200-54	54	0.0566	50	2.500	2.000	0.500	0.416	1.41	2.237
250S200-68	68	0.0713	50	2.500	2.000	0.500	0.519	1.77	2.207
250S250-43	43	0.0451	33	2.500	2.500	0.500	0.379	1.29	2.260
250S250-54	54	0.0566	50	2.500	2.500	0.500	0.472	1.61	2.237
250S250-68	68	0.0713	50	2.500	2.500	0.500	0.590	2.01	2.207
362S162-33	33	0.0346	33	3.625	1.625	0.500	0.262	0.89	3.406
362S162-43	43	0.0451	33	3.625	1.625	0.500	0.339	1.16	3.385
362S162-54	54	0.0566	50	3.625	1.625	0.500	0.423	1.44	3.362
362S162-68	68	0.0713	50	3.625	1.625	0.500	0.528	1.80	3.332
362S200-33	33	0.0346	33	3.625	2.000	0.625	0.297	1.01	3.406
362S200-43	43	0.0451	33	3.625	2.000	0.625	0.385	1.31	3.385
362S200-54	54	0.0566	50	3.625	2.000	0.625	0.479	1.63	3.362
362S200-68	68	0.0713	50	3.625	2.000	0.625	0.599	2.04	3.332
362S250-43	43	0.0451	33	3.625	2.500	0.625	0.430	1.46	3.385
362S250-54	54	0.0566	50	3.625	2.500	0.625	0.536	1.82	3.362
362S250-68	68	0.0713	50	3.625	2.500	0.625	0.670	2.28	3.332
400S162-33	33	0.0346	33	4.000	1.625	0.500	0.275	0.94	3.781
400S162-43	43	0.0451	33	4.000	1.625	0.500	0.356	1.21	3.760
400S162-54	54	0.0566	50	4.000	1.625	0.500	0.444	1.51	3.737
400S162-68	68	0.0713	50	4.000	1.625	0.500	0.554	1.89	3.707
400S200-33	33	0.0346	33	4.000	2.000	0.625	0.310	1.05	3.781
400S200-43	43	0.0451	33	4.000	2.000	0.625	0.401	1.37	3.760
400S200-54	54	0.0566	50	4.000	2.000	0.625	0.501	1.70	3.737
400S200-68	68	0.0713	50	4.000	2.000	0.625	0.626	2.13	3.707
400S250-43	43	0.0451	33	4.000	2.500	0.625	0.447	1.52	3.760
400S250-54	54	0.0566	50	4.000	2.500	0.625	0.557	1.90	3.737
400S250-68	68	0.0713	50	4.000	2.500	0.625	0.697	2.37	3.707
600S162-33	33	0.0346	33	6.000	1.625	0.500	0.344	1.17	5.781
600S162-43	43	0.0451	33	6.000	1.625	0.500	0.447	1.52	5.760
600S162-54	54	0.0566	50	6.000	1.625	0.500	0.557	1.90	5.737
600S162-68	68	0.0713	50	6.000	1.625	0.500	0.697	2.37	5.707
600S200-33	33	0.0346	33	6.000	2.000	0.625	0.379	1.29	5.781
600S200-43	43	0.0451	33	6.000	2.000	0.625	0.492	1.67	5.760
600S200-54	54	0.0566	50	6.000	2.000	0.625	0.614	2.09	5.737
600S200-68	68	0.0713	50	6.000	2.000	0.625	0.768	2.61	5.707
600S250-43	43	0.0451	33	6.000	2.500	0.625	0.537	1.83	5.760
600S250-54	54	0.0566	50	6.000	2.500	0.625	0.670	2.28	5.737
600S250-68	68	0.0713	50	6.000	2.500	0.625	0.840	2.86	5.707



TABLE 2 -- DIGITAL BUILDING COMPONENTS STUD PROFILE SUMMARY ^{1,3} (Continued)

Product Designation	Mils	Design Thickness (in)	F _y (ksi)	Web Depth ² (in.)	Flange Width (in.)	Lip Size (in.)	Area (in ²)	Weight (lb/ft)	Flat Web Height ⁴ (in)
800S162-33	33	0.0346	33	8.000	1.625	0.500	0.414	1.41	7.781
800S162-43	43	0.0451	33	8.000	1.625	0.500	0.537	1.83	7.760
800S162-54	54	0.0566	50	8.000	1.625	0.500	0.670	2.28	7.737
800S162-68	68	0.0713	50	8.000	1.625	0.500	0.840	2.86	7.707
800S200-33	33	0.0346	33	8.000	2.000	0.625	0.448	1.53	7.781
800S200-43	43	0.0451	33	8.000	2.000	0.625	0.582	1.98	7.760
800S200-54	54	0.0566	50	8.000	2.000	0.625	0.727	2.47	7.737
800S200-68	68	0.0713	50	8.000	2.000	0.625	0.911	3.10	7.707
800S250-43	43	0.0451	33	8.000	2.500	0.625	0.627	2.13	7.760
800S250-54	54	0.0566	50	8.000	2.500	0.625	0.784	2.67	7.737
800S250-68	68	0.0713	50	8.000	2.500	0.625	0.982	3.34	7.707
1000S162-33	33	0.0346	33	10.000	1.625	0.500	0.483	1.64	9.781
1000S162-43	43	0.0451	33	10.000	1.625	0.500	0.627	2.13	9.760
1000S162-54	54	0.0566	50	10.000	1.625	0.500	0.784	2.67	9.737
1000S162-68	68	0.0713	50	10.000	1.625	0.500	0.982	3.34	9.707
1000S200-33	33	0.0346	33	10.000	2.000	0.625	0.517	1.76	9.781
1000S200-43	43	0.0451	33	10.000	2.000	0.625	0.672	2.29	9.760
1000S200-54	54	0.0566	50	10.000	2.000	0.625	0.840	2.86	9.737
1000S200-68	68	0.0713	50	10.000	2.000	0.625	1.053	3.58	9.707
1000S250-43	43	0.0451	33	10.000	2.500	0.625	0.717	2.44	9.760
1000S250-54	54	0.0566	50	10.000	2.500	0.625	0.897	3.05	9.737
1000S250-68	68	0.0713	50	10.000	2.500	0.625	1.125	3.83	9.707
1200S162-33	33	0.0346	33	12.000	1.625	0.500	0.552	1.88	11.781
1200S162-43	43	0.0451	33	12.000	1.625	0.500	0.717	2.44	11.760
1200S162-54	54	0.0566	50	12.000	1.625	0.500	0.897	3.05	11.737
1200S162-68	68	0.0713	50	12.000	1.625	0.500	1.125	3.83	11.707
1200S200-33	33	0.0346	33	12.000	2.000	0.625	0.587	2.00	11.781
1200S200-43	43	0.0451	33	12.000	2.000	0.625	0.762	2.59	11.760
1200S200-54	54	0.0566	50	12.000	2.000	0.625	0.953	3.24	11.737
1200S200-68	68	0.0713	50	12.000	2.000	0.625	1.196	4.07	11.707
1200S250-43	43	0.0451	33	12.000	2.500	0.625	0.807	2.75	11.760
1200S250-54	54	0.0566	50	12.000	2.500	0.625	1.010	3.44	11.737
1200S250-68	68	0.0713	50	12.000	2.500	0.625	1.267	4.31	11.707

¹ Figure 1 of this report illustrates the Section Profiles.

² Web height is measured from the outside face to the outside face of the flanges.

³ Table 1 of this report lists design thickness, minimum thickness, and inside bend radius.

⁴ Flat web height (h) is the flat dimension of the web for use in web crippling calculations.



TABLE 3 -- DIGITAL BUILDING COMPONENTS TRACK PROFILE SUMMARY ^{1,3}

Product Designation	Mils	Design Thickness (in)	F _y (ksi)	Web Depth ² (in.)	Flange Width (in.)	Lip Size (in.)	Area (in ²)	Weight (lb/ft)	Flat Web Height ⁴ (in)
250T150-33	33	0.0346	33	2.500	1.500	-	0.188	0.64	2.350
250T150-43	43	0.0451	33	2.500	1.500	-	0.244	0.83	2.350
250T150-54	54	0.0566	50	2.500	1.500	-	0.306	1.04	2.350
250T150-68	68	0.0713	50	2.500	1.500	-	0.385	1.31	2.350
250T200-33	33	0.0346	33	2.500	2.000	-	0.222	0.76	2.350
250T200-43	43	0.0451	33	2.500	2.000	-	0.289	0.98	2.350
250T200-54	54	0.0566	50	2.500	2.000	-	0.363	1.23	2.350
250T200-68	68	0.0713	50	2.500	2.000	-	0.457	1.55	2.350
250T250-43	43	0.0451	33	2.500	2.500	-	0.334	1.14	2.350
250T250-54	54	0.0566	50	2.500	2.500	-	0.419	1.43	2.350
250T250-68	68	0.0713	50	2.500	2.500	-	0.528	1.80	2.350
250T300-54	54	0.0566	50	3.000	2.000	-	0.363	1.23	2.850
250T300-68	68	0.0713	50	3.000	2.000	-	0.457	1.55	2.850
266T200-33	33	0.0346	33	2.656	2.000	-	0.279	0.95	2.506
266T200-43	43	0.0451	33	2.656	2.000	-	0.364	1.24	2.506
266T200-54	54	0.0566	50	2.656	2.000	-	0.457	1.55	2.506
266T200-68	68	0.0713	50	2.656	2.000	-	0.575	1.96	2.506
266T250-43	43	0.0451	33	2.656	2.500	-	0.347	1.18	2.506
266T250-54	54	0.0566	50	2.656	2.500	-	0.435	1.48	2.506
266T250-68	68	0.0713	50	2.656	2.500	-	0.548	1.86	2.506
266T300-54	54	0.0566	50	2.656	3.000	-	0.435	1.48	2.506
266T300-68	68	0.0713	50	2.656	3.000	-	0.548	1.86	2.506
362T150-33	33	0.0346	33	3.625	1.500	-	0.226	0.77	3.475
362T150-43	43	0.0451	33	3.625	1.500	-	0.295	1.00	3.475
362T150-54	54	0.0566	50	3.625	1.500	-	0.370	1.26	3.475
362T150-68	68	0.0713	50	3.625	1.500	-	0.466	1.58	3.475
362T200-33	33	0.0346	33	3.625	2.000	-	0.261	0.89	3.475
362T200-43	43	0.0451	33	3.625	2.000	-	0.340	1.16	3.475
362T200-54	54	0.0566	50	3.625	2.000	-	0.427	1.45	3.475
362T200-68	68	0.0713	50	3.625	2.000	-	0.537	1.83	3.475
362T250-43	43	0.0451	33	3.625	2.500	-	0.385	1.31	3.475
362T250-54	54	0.0566	50	3.625	2.500	-	0.483	1.64	3.475
362T250-68	68	0.0713	50	3.625	2.500	-	0.608	2.07	3.475
362T300-54	54	0.0566	50	3.625	3.000	-	0.540	1.84	3.475
362T300-68	68	0.0713	50	3.625	3.000	-	0.679	2.31	3.475
378T200-33	33	0.0346	33	3.781	2.000	-	0.266	0.91	3.631
378T200-43	43	0.0451	33	3.781	2.000	-	0.347	1.18	3.631
378T200-54	54	0.0566	50	3.781	2.000	-	0.435	1.48	3.631
378T200-68	68	0.0713	50	3.781	2.000	-	0.548	1.86	3.631
378T250-43	43	0.0451	33	3.781	2.500	-	0.347	1.18	3.631
378T250-54	54	0.0566	50	3.781	2.500	-	0.435	1.48	3.631
378T250-68	68	0.0713	50	3.781	2.500	-	0.548	1.86	3.631
378T300-54	54	0.0566	50	3.781	3.000	-	0.435	1.48	3.631
378T300-68	68	0.0713	50	3.781	3.000	-	0.548	1.86	3.631



TABLE 3 – DIGITAL BUILDING COMPONENTS TRACK PROFILE SUMMARY ^{1,3} (Continued)

Product Designation	Mils	Design Thickness (in)	F _y (ksi)	Web Depth ² (in.)	Flange Width (in.)	Lip Size (in.)	Area (in ²)	Weight (lb/ft)	Flat Web Height ⁴ (in)
400T150-33	33	0.0346	33	4.000	1.500	-	0.239	0.81	3.850
400T150-43	43	0.0451	33	4.000	1.500	-	0.312	1.06	3.850
400T150-54	54	0.0566	50	4.000	1.500	-	0.391	1.33	3.850
400T150-68	68	0.0713	50	4.000	1.500	-	0.492	1.68	3.850
400T200-33	33	0.0346	33	4.000	2.000	-	0.274	0.93	3.850
400T200-43	43	0.0451	33	4.000	2.000	-	0.357	1.21	3.850
400T200-54	54	0.0566	50	4.000	2.000	-	0.448	1.52	3.850
400T200-68	68	0.0713	50	4.000	2.000	-	0.564	1.92	3.850
400T250-43	43	0.0451	33	4.000	2.500	-	0.402	1.37	3.850
400T250-54	54	0.0566	50	4.000	2.500	-	0.504	1.72	3.850
400T250-68	68	0.0713	50	4.000	2.500	-	0.635	2.16	3.850
400T300-54	54	0.0566	50	4.000	3.000	-	0.561	1.91	3.850
400T300-68	68	0.0713	50	4.000	3.000	-	0.706	2.40	3.850
416T200-33	33	0.0346	33	4.156	2.000	-	0.279	0.95	4.006
416T200-43	43	0.0451	33	4.155	2.000	-	0.364	1.24	4.005
416T200-54	54	0.0566	50	4.156	2.000	-	0.457	1.55	4.006
416T200-68	68	0.0713	50	4.156	2.000	-	0.575	1.96	4.006
416T250-43	43	0.0451	33	4.156	2.500	-	0.347	1.18	4.006
416T250-54	54	0.0566	50	4.156	2.500	-	0.435	1.48	4.006
416T250-68	68	0.0713	50	4.156	2.500	-	0.548	1.86	4.006
416T300-54	54	0.0566	50	4.156	3.000	-	0.435	1.48	4.006
416T300-68	68	0.0713	50	4.156	3.000	-	0.548	1.86	4.006
600T150-33	33	0.0346	33	6.000	1.500	-	0.309	1.05	5.85
600T150-43	43	0.0451	33	6.000	1.500	-	0.402	1.37	5.85
600T150-54	54	0.0566	50	6.000	1.500	-	0.504	1.72	5.85
600T150-68	68	0.0713	50	6.000	1.500	-	0.635	2.16	5.85
600T200-33	33	0.0346	33	6.000	2.000	-	0.343	1.17	5.85
600T200-43	43	0.0451	33	6.000	2.000	-	0.447	1.52	5.85
600T200-54	54	0.0566	50	6.000	2.000	-	0.561	1.91	5.85
600T200-68	68	0.0713	50	6.000	2.000	-	0.706	2.40	5.85
600T250-43	43	0.0451	33	6.000	2.500	-	0.492	1.68	5.85
600T250-54	54	0.0566	50	6.000	2.500	-	0.618	2.10	5.85
600T250-68	68	0.0713	50	6.000	2.500	-	0.778	2.65	5.85
600T300-54	54	0.0566	50	6.000	3.000	-	0.674	2.29	5.85
600T300-68	68	0.0713	50	6.000	3.000	-	0.849	2.89	5.85
616T200-33	33	0.0346	33	6.156	2.000	-	0.349	1.19	6.006
616T200-43	43	0.0451	33	6.155	2.000	-	0.454	1.55	6.005
616T200-54	54	0.0566	50	6.156	2.000	-	0.570	1.94	6.006
616T200-68	68	0.0713	50	6.156	2.000	-	0.717	2.44	6.006
616T250-43	43	0.0451	33	6.156	2.500	-	0.347	1.18	6.006
616T250-54	54	0.0566	50	6.156	2.500	-	0.435	1.48	6.006
616T250-68	68	0.0713	50	6.156	2.500	-	0.548	1.86	6.006
616T300-54	54	0.0566	50	6.156	3.000	-	0.435	1.48	6.006
616T300-68	68	0.0713	50	6.156	3.000	-	0.548	1.86	6.006



TABLE 3 -- DIGITAL BUILDING COMPONENTS TRACK PROFILE SUMMARY ^{1,3} (Continued)

Product Designation	Mils	Design Thickness (in)	F _y (ksi)	Web Depth ² (in.)	Flange Width (in.)	Lip Size (in.)	Area (in ²)	Weight (lb/ft)	Flat Web Height ⁴ (in)
800T150-33	33	0.0346	33	8.000	1.500	-	0.378	1.29	7.850
800T150-43	43	0.0451	33	8.000	1.500	-	0.492	1.68	7.850
800T150-54	54	0.0566	50	8.000	1.500	-	0.618	2.10	7.850
800T150-68	68	0.0713	50	8.000	1.500	-	0.778	2.65	7.850
800T200-33	33	0.0346	33	8.000	2.000	-	0.412	1.40	7.850
800T200-43	43	0.0451	33	8.000	2.000	-	0.537	1.83	7.850
800T200-54	54	0.0566	50	8.000	2.000	-	0.674	2.29	7.850
800T200-68	68	0.0713	50	8.000	2.000	-	0.849	2.89	7.850
800T250-43	43	0.0451	33	8.000	2.500	-	0.583	1.98	7.850
800T250-54	54	0.0566	50	8.000	2.500	-	0.731	2.49	7.850
800T250-68	68	0.0713	50	8.000	2.500	-	0.920	3.13	7.850
800T300-54	54	0.0566	50	8.000	3.000	-	0.787	2.68	7.850
800T300-68	68	0.0713	50	8.000	3.000	-	0.991	3.37	7.850
816T200-33	33	0.0346	33	8.156	2.000	-	0.418	1.42	8.006
816T200-43	43	0.0451	33	8.155	2.000	-	0.544	1.85	8.005
816T200-54	54	0.0566	50	8.156	2.000	-	0.683	2.32	8.006
816T200-68	68	0.0713	50	8.156	2.000	-	0.860	2.93	8.006
816T250-43	43	0.0451	33	8.156	2.500	-	0.347	1.18	8.006
816T250-54	54	0.0566	50	8.156	2.500	-	0.435	1.48	8.006
816T250-68	68	0.0713	50	8.156	2.500	-	0.548	1.86	8.006
816T300-54	54	0.0566	50	8.156	3.000	-	0.435	1.48	8.006
816T300-68	68	0.0713	50	8.156	3.000	-	0.548	1.86	8.006
1000T150-33	33	0.0346	33	10.000	1.500	-	0.447	1.52	9.850
1000T150-43	43	0.0451	33	10.000	1.500	-	0.583	1.98	9.850
1000T150-54	54	0.0566	50	10.000	1.500	-	0.731	2.49	9.850
1000T150-68	68	0.0713	50	10.000	1.500	-	0.920	3.13	9.850
1000T200-33	33	0.0346	33	10.000	2.000	-	0.482	1.64	9.850
1000T200-43	43	0.0451	33	10.000	2.000	-	0.628	2.14	9.850
1000T200-54	54	0.0566	50	10.000	2.000	-	0.787	2.68	9.850
1000T200-68	68	0.0713	50	10.000	2.000	-	0.991	3.37	9.850
1000T250-43	43	0.0451	33	10.000	2.500	-	0.673	2.29	9.850
1000T250-54	54	0.0566	50	10.000	2.500	-	0.844	2.87	9.850
1000T250-68	68	0.0713	50	10.000	2.500	-	1.063	3.62	9.850
1000T300-54	54	0.0566	50	10.000	3.000	-	0.901	3.06	9.850
1000T300-68	68	0.0713	50	10.000	3.000	-	1.134	3.86	9.850



TABLE 3 -- DIGITAL BUILDING COMPONENTS TRACK PROFILE SUMMARY ^{1,3} (Continued)

Product Designation	Mils	Design Thickness (in)	F _y (ksi)	Web Depth ² (in.)	Flange Width (in.)	Lip Size (in.)	Area (in ²)	Weight (lb/ft)	Flat Web Height ⁴ (in)
1200T150-33	33	0.0346	33	12.000	1.500	-	0.516	1.76	11.850
1200T150-43	43	0.0451	33	12.000	1.500	-	0.673	2.29	11.850
1200T150-54	54	0.0566	50	12.000	1.500	-	0.844	2.87	11.850
1200T150-68	68	0.0713	50	12.000	1.500	-	1.063	3.62	11.850
1200T200-33	33	0.0346	33	12.000	2.000	-	0.551	1.87	11.850
1200T200-43	43	0.0451	33	12.000	2.000	-	0.718	2.44	11.850
1200T200-54	54	0.0566	50	12.000	2.000	-	0.901	3.06	11.850
1200T200-68	68	0.0713	50	12.000	2.000	-	1.134	3.86	11.850
1200T250-43	43	0.0451	33	12.000	2.500	-	0.763	2.60	11.850
1200T250-54	54	0.0566	50	12.000	2.500	-	0.957	3.26	11.850
1200T250-68	68	0.0713	50	12.000	2.500	-	1.205	4.10	11.850
1200T300-54	54	0.0566	50	12.000	3.000	-	1.014	3.45	11.850
1200T300-68	68	0.0713	50	12.000	3.000	-	1.277	4.34	11.850

¹ Figure 1 of this report illustrates Section Profiles.

² Web height is measured from the inside face to the inside face of flanges.

³ Table 1 of this report lists design thickness, minimum thickness, and inside bend radius.

⁴ Flat web height (h) is the flat dimension of the web for use in web crippling calculations.