



SIDEPLATE SYSTEMS, INC.

25909 Pala, Suite 200

Mission Viejo, CA 92691

949-238-8900

www.sideplate.com

SIDEPLATE STEEL FRAME CONNECTION TECHNOLOGY: FIELD-WELDED AND FIELD-BOLTED CONNECTIONS

CSI Section:

05 12 00 Structural Steel Framing

1.0 RECOGNITION

SidePlate Steel Frame Connection Technology described in this report has been evaluated for use as beam-to-column connections with Special Moment Frames (SMF) and Intermediate Moment Frames (IMF) in uniaxial and biaxial arrangements. The structural performance properties of the SidePlate Steel Frame Connection Technology comply with the intent of the provisions of the following codes and regulations:

- 2021, 2018, 2015, and 2012 International Building Code® (IBC)
- 2022 and 2019 California Building Code (CBC) – attached Supplement
- 2023 and 2020 City of Los Angeles Building Code (LABC) – attached Supplement

2.0 LIMITATIONS

Use of the SidePlate Steel Frame Connection Technology recognized in this report is subject to the following limitations:

2.1 All connections and details of SidePlate Systems shall be designed by a registered design professional working on behalf of SidePlate Systems, and the design documents shall be submitted to the project’s registered design professional (engineer of record) for acceptance and to the building official for approval as described in Section 3.2.10 of this report.

2.2 Structural design drawings and specifications, shop drawings, and erection drawings shall comply with Section 1603 of the 2021, 2018, 2015, and 2012 IBC, Sections A4 and I1 of AISC 341-16 and Section A4 of AISC 360-16.

2.3 Fabrication of the SidePlate Moment Connection assemblies shall comply with Section 3.3 of this report and approved construction drawings specified by SidePlate

Systems, Inc. as “SP General Notes”, and shall be either performed on the premises of a fabricator registered and approved by the building official in accordance with Section 1704.2.5.1 of the 2021, 2018, and 2015 IBC (Section 1704.2.5.2 of the 2012 IBC) or as specified in Section 3.1 of this report.

2.4 Erection shall comply with Section 3.4 of this report and the approved construction drawings prepared by a registered design professional and specified by SidePlate Systems, Inc. as “SP General Notes”.

2.5 Quality control and quality assurance shall comply with Section 3.5 of this report and approved construction drawings specified by SidePlate Systems, Inc. as “SP General Notes”.

3.0 PRODUCT USE

3.1 General: SidePlate Steel Frame Connection Technology complies with Chapter 22 of the 2021, 2018, 2015, and 2012 IBC and Sections E2, E3, and K2 of AISC 341-16. The SidePlate moment connection is prequalified for use in Special Moment Frame (SMF) and Intermediate Moment Frame (IMF) systems within the limits stated in Sections 3.2.2 through 3.2.8 of this report. The connection of the beam to the column is accomplished with parallel full-depth side plates that sandwich and connect the beam(s) and the column together. The connection uses a physical separation, or gap, between the face of the column flange and the end of the beam. Both field-welded and field-bolted options are available as shown in Figures 1 and 2 of this report. The field bolted option is available in three configurations, referred to as Configuration A (Standard), Configuration B (Narrow), and Configuration C (Tuck) as shown in Figure 3 of this report. In the field-welded connection, top and bottom beam flange cover plates are used at the end of the beam, as applicable, to bridge any difference between the flange widths of the beam(s) and of the column. In the field-bolted connection, beam flanges are connected to the side plates with either a cover plate or pair of angles and high-strength pretensioned bolts as shown in Figure 10 of this report.

Figure 4 of this report shows the connection geometry and major connection components for uniaxial field-welded configurations.

Figure 5 of this report shows the connection geometry and major connection components for biaxial configurations with built-up flanged cruciform sections, which permits connecting up to four beams to a column. Figure 6 of this report shows analogous biaxial configurations with built-up box, and HSS sections. HSS columns may be filled with concrete if needed. All field-bolted beam configurations as shown in Figure 3 of this report and field-welded configurations are permitted in biaxial applications.

The product described in this Uniform Evaluation Service (UES) Report has been evaluated as an alternative material, design or method of construction in order to satisfy and comply with the intent of the provision of the code, as noted in this report, and for at least equivalence to that prescribed in the code in quality, strength, effectiveness, fire resistance, durability and safety, as applicable, in accordance with IBC Section 104.11. This document shall only be reproduced in its entirety.

Copyright © 2023 by International Association of Plumbing and Mechanical Officials. All rights reserved. Printed in the United States. Ph: 1-877-4IESRPT • Fax: 909.472.4171
web: www.uniform-es.org • 4755 East Philadelphia Street, Ontario, California 91761-2816 – USA

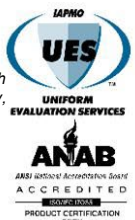



The biaxial side plate assembly is comprised of two intersecting side plates that are connected to the HSS or built-up box or boxed I-shaped columns as shown in Figure 7(a) of this report. Each side plate is slotted to accommodate the other orthogonal side plate as shown in Figures 7(b) and 7(c) of this report.

3.2 Design and Installation

3.2.1 General: The design of the structural steel seismic force-resisting systems shall comply with Chapter 22 of the 2021, 2018, 2015, and 2012 IBC. The SMF and IMF shall be designed and detailed in accordance with the specific requirements for the system as set forth in Table 12.2-1 of ASCE 7-16. The design of structural welds used in the SidePlate Steel Frame Connection Technology shall comply with ANSI/AWS D1.1-2015 (AWS D1.1) and ANSI/AWS D1.8:2016 for the 2021, 2018, 2015, and 2012 IBC using the design provisions in Sections 3.2.2 through 3.2.8 of this report.

3.2.2 Connection Properties: The structural model used for lateral load-resisting beams and columns shall incorporate stiffened beam end properties of approximately three times the moment of inertia of the beam and a 100 percent rigid offset in the panel zone.

3.2.3 Plastic Hinge Location: The location of the plastic hinge shall be taken as one-third of the beam or girder depth for the field-welded connection and one-sixth of the beam or girder depth for the field-bolted connection from the end of the side plates farthest from the column.

3.2.4 Required Shear Strength at Plastic Hinge: The required shear strength at the plastic hinge, V_h , shall be based on applying gravity loads acting on the beam and the probable maximum moment at the hinge complying with Sections E2.6d and E3.6d of AISC 341-16 for the 2021, 2018, 2015, and 2012 IBC and as follows:

$$V_h = \frac{2M_{pr}}{L_h} + V_{gravity}, \quad \text{kips (N)} \quad (\text{Eq-1})$$

where

- L_h = distance between plastic hinge locations, in. (mm)
- M_{pr} = probable maximum moment at the plastic hinge, kip-in. (N-mm)
- $V_{gravity}$ = beam shear force resulting from $1.2D + f_1L + 0.2S$ (where f_1 is the load factor determined by the applicable building code given in Section 1.0 of this report for live loads, but not less than 0.5), kips (N)

3.2.5 Beam Limitations: Beams forming the moment frame shall satisfy the following limitations:

- (1) Beams shall be rolled wide flange, hollow structural sections (HSS), or built-up I-shaped beams

conforming to the requirements of Section 4.2.1 of this report.

- (2) Rolled and built-up wide-flange beam depth shall be limited to W40 (W1000) and W48 (W1200) maximum for the field-welded and field-bolted connections, respectively.
- (3) For SMF and IMF, HSS beam depths shall be limited to HSS14 (HSS356) and HSS16 (HSS 406) maximum, respectively.
- (4) Rolled and built-up wide-flange beam weight shall be limited to 302 lb/ft (449 kg/m) and 529 lb/ft (787 kg/m) maximum for the field-welded and field-bolted connections, respectively.
- (5) The ratio of the beam span is the distance between the locations of the plastic hinge to beam depth (L_h/d) shall be limited as follows:
 - (a) For SMF systems, 4.5 and 3.5 or greater for field-welded and field-bolted connections, respectively.
 - (b) For IMF systems, 3 or greater.
- (6) The width-to-thickness ratios for beam flanges and webs shall conform to the limits of Sections E2.5a and E3.5a of AISC 341-16 for the 2021, 2018, 2015, and 2012 IBC.
- (7) Lateral bracing of beams shall be provided as follows:
 - (a) For SMF systems using the beams described in Section 3.2.5 (1) of this report, lateral bracing shall comply with Sections D1.2 and E3.4b of AISC 341-16 for the 2021, 2018, 2015, and 2012 IBC, where the length of the beam is defined as the distance between the ends of the SidePlate connections and the segment of the beam connected to the side plates shall be considered to be braced. As required by AISC 341-16, no additional lateral bracing is required at or near the plastic hinge.
 - (b) For IMF systems using the beams described in Section 3.2.5 (1) of this report shall comply with Sections D1.2 and E2.4a of AISC 341-16 for the 2021, 2018, 2015, and 2012 IBC, where the same lateral bracing provisions apply as for SMF systems.
- (8) The protected zone in the beam for the field-welded and field-bolted connections shall consist of the portion of the beam as shown in Figures 8 and 9 of this report, respectively.

3.2.6 Column Limitations: Columns forming the moment frame shall satisfy the following limitations:

- (1) Columns shall be any of the rolled shapes, built-up box, boxed I-shaped, hollow structural section (HSS), built-up I-shaped sections, and/or flanged cruciform sections consisting of rolled shapes or built-up from plates conforming to the requirements of Section 4.2.1



of this report. Flange and web plates of built-up box columns may continuously be connected by fillet welds or PJP groove welds along the length of the column.

- (2) The beam shall be connected to the side plates that are connected to the flange tips of the wide flange or corners/sides of HSS or built-up box columns.
- (3) The rolled shape column depth shall be limited to W44 (W1100) maximum. The depth of built-up wide-flange columns shall not exceed that for rolled shapes of 44 inches (1100 mm). Built-up box columns shall not have a width exceeding 36 in. (914 mm).
- (4) There is no limit on column weight per foot.
- (5) There are no additional requirements for column flange thickness.
- (6) Width-to-thickness ratios for the flanges and webs of columns shall conform to the requirements of Sections D1.1, E2.5a (for IMF Systems), and E3.5a (for SMF Systems) of AISC 341-16 for the 2021, 2018, 2015, and 2012 IBC. Table D1.1 of AISC 341-16 is modified to allow the limiting width-thickness ratio for walls of rectangular HSS columns to be computed as follows: $b/t \leq 0.87(E/F_y)^{1/2}$, or 21, whichever is less.
- (7) Lateral bracing of columns for SMF shall conform to the requirements in Section E3.4c of AISC 341-16 for the 2021, 2018, 2015, and 2012 IBC.

3.2.7 Connection Limitations: The SidePlate Moment Connections shall comply with the following limitations:

- (1) All SidePlate connection plates, which consist of side plates, cover plates, horizontal shear plates, and vertical shear elements (if applicable), shall be fabricated from structural steel specified in Section 4.2.2 of this report.
- (2) HSS column shapes shall conform to the material specified in Section 4.2.1 of this report.
- (3) The extension of the side plates beyond the face of the column shall be within the range of $0.65d$ to $1.0d$ and $0.65d$ to $1.7d$, for the field-welded and field-bolted connections, respectively. Where d is the nominal depth of the beam.
- (4) The protected zone on the beam for the field-welded and field-bolted connections shall consist of the portion of the beam as shown in Figures 8 and 9 of this report. The protected zone on the side plate shall consist of a region that is 6 inches (150 mm) deep at the top and bottom of the side plate that starts at the inside face of the flange of a wide-flange or HSS column and ends either at the end of the gap (field-welded) or the edge of the first bolt hole (field-bolted) as shown in Figures 8 and 9 of this report.
- (5) SidePlate connections may be designed with or without vertical shear elements depending on the size of the beam and column.

3.2.8 Column-Beam Relationship Limitations: Column-to-beam connections shall satisfy the following limitations:

- (1) Beam flange width and thickness for rolled, built-up, and HSS shapes shall satisfy the following equations for geometric compatibility:

- (a) Field-welded Connection

$$\begin{aligned} b_{bf} + 1.1 * t_{bf} + 1/2 \text{ in.} &\leq b_{cf} \\ b_{bf} + 1.1 * t_{bf} + 12 \text{ mm} &\leq b_{cf} \end{aligned} \quad (\text{Eq-2})$$

- (b) Field-bolted Connection

$$\begin{aligned} b_{bf} + 1 \text{ in.} &\leq b_{cf} \\ b_{bf} + 25 \text{ mm} &\leq b_{cf} \end{aligned} \quad (\text{Eq-3})$$

where:

$$\begin{aligned} b_{bf} &= \text{width of beam flange, in. (mm)} \\ b_{cf} &= \text{width of column flange, in. (mm)} \\ t_{bf} &= \text{thickness of beam flange, in. (mm)} \end{aligned}$$

- (2) Panel zones shall conform to the applicable requirements of the AISC 341-16.
- (3) Column-beam moment ratios shall be limited as follows:

- (a) For SMF systems, the column-beam moment ratio shall conform to the following relationship:

$$\frac{\sum M_{pc}^*}{\sum M_{pb}^*} \geq 1.0 \quad (\text{Eq-4})$$

where:

For the uniaxial connection the value of $\sum M_{pc}^*$ = the sum of the projections of the nominal flexural strengths (M_{pc}) of the column above and below the connection joint, at the location of theoretical hinge formation in the column (i.e., one-quarter of the column depth above and below the extreme fibers of the side plates), to the beam centerline, with a reduction for the axial force in the column. The nominal flexural strength of the column shall be computed as:

$$\sum M_{pc}^* = \sum Z_{ec} (F_{yc} - P_{uc}/A_g) \quad (\text{Eq-5})$$

F_{yc} = The minimum specified yield strength of the column at the connection, ksi (MPa)

P_{uc}/A_g = Ratio of column axial compressive load, computed in accordance with load and resistance factor (LRFD) provisions, to the gross area of the column, ksi (MPa)

Z_c = Plastic section modulus of the column, in.³ (mm³)

Z_{ec} = The equivalent plastic section modulus of column (Z_c) at a distance of 1/4 column depth from the top and bottom edges of side plates, projected to beam centerline, in.³ (mm³),



and computed as:

$$Z_{ec} = \frac{Z_c(H/2)}{H_h/2} = \frac{Z_c H}{H_h} \quad (\text{Eq-6})$$

where:

- H = story height, in. (mm)
- H_h = distance along column height from 1/4 of column depth *above* the top edge of lower story side plates to 1/4 of column depth below the bottom edge of upper story side plates, in. (mm)
- $\sum M_{pb}^*$ = The sum of the projections of the expected flexural strengths of the beam(s) at the plastic hinge locations to the *column* centerline. The expected flexural strength of the beam shall be computed as:

$$\sum M_{pb}^* = \sum (1.1R_y F_{yb} Z_b + M_v) \quad (\text{Eq-7})$$
- F_{yb} = *Specified* minimum yield stress of beam, ksi (MPa)
- M_v = Additional moment due to shear amplification from the *location* of the plastic hinge to the column centerline based on LRFD load combinations, kip-in (N-mm).
- R_y = ratio of expected yield stress to specified minimum yield stress F_y as specified in the AISC 341-16
- Z_b = *nominal* plastic section modulus of the beam, in.³ (mm³)

The column-beam moment ratio for the biaxial configuration is checked by the methodology that has been internally developed by SidePlate Systems, Inc. For this purpose, it shall be permitted to take the actual yield strength of the column material as the specified yield strength and to consider the full composite behavior of the column for axial and flexural loading action if it is filled with concrete. For a preliminary design, the column-beam moment ratio may be checked using AISC 341-16 similar to other biaxial connections with improved equivalent plastic section modulus of column per Eq-6 of this report.

3.2.9 Surrounding Elements: The design of supporting and supported elements and connections to the SidePlate Connection System, shall comply with the provisions of the IBC, including Chapter 19 for concrete, Chapter 21 for masonry, and Chapter 22 for steel. Provisions for non-participating supported components in Section 12.12 of ASCE 7 shall apply. Column bases to concrete and masonry shall be designed and detailed to preclude brittle failure.

3.2.10 Design Responsibility: SidePlate Systems assists the engineer of record with the verification of final beam and column sizes selected for the steel lateral load resisting system using the SidePlate Connection System. Upon completion of the preliminary selection of lateral load-

resisting frame beam and column member sizes using the SidePlate Connection System, the engineer of record submits a computer model to SidePlate Systems, Inc. satisfying the provisions stated in Sections 3.2.4 through 3.2.8 of this report, as applicable. Upon completion of the mathematical model review and after additional information has been supplied by the engineer of record, SidePlate engineers provide project-specific connection designs. SidePlate engineers design all connection elements per the design procedures contained in SidePlate Connection Design Software (Version 16 for field-welded and Version 17 for field-bolted connections). The version shall be clearly identified on each page of the calculations. The final design includes structural notes and details for connections. Finally, the engineer of record reviews calculations and drawings prepared by SidePlate Systems to ensure that all project-specific connection designs have been adequately designed and detailed based on the preliminary selection of beam and column members.

3.3 Fabrication: The SidePlate Connection System components shall be manufactured by an approved fabricator in accordance with Section 1704.2.5.1 of the 2021 and 2018 IBC, and Section 1704 of the 2015 and 2012 IBC. To demonstrate the ability to produce sound welds, all welders, welding operators, and tack welders shall be qualified in conformance with AWS D1.1, Clause 4, Part C. Welders and welding operators performing welds as described in AWS D1.8 Clause 5.1.1 shall be subjected to Supplemental Welder Qualification Testing in accordance with AWS D1.8 Chapter 5.

Welding shall be performed in accordance with a Welding Procedure Specification (WPS) in accordance with AWS D1.1 which shall be prepared for every different welding application including welding position, welding process, electrode manufacturer, filler metal trade name for the electrode type selected, and other essential variables as defined in AWS D1.1. In addition, for demand critical welds, supplemental requirements in Clause 6.1 of AWS D1.8 apply.

3.4 Erection: Erection of the SidePlate Connection System shall be in accordance with Chapter N of AISC 360, AISC 303-16, and Chapters I and J of AISC 341-16 for Chapter 22 of the 2021, 2018, 2015, and 2012 IBC. Moment frames that utilize the SidePlate connection may be constructed using one of three methods: (1) the full-length beam erection method; (2) the link-beam erection method; (3) fully shop prefabricated, multi-bay, and multistory moment frame method, with no field welding required.

The SidePlate Connection System may be used in new, typical and traditional construction practices. Additionally, it may be used for retrofitting existing beam-to-column moment connections. The registered design professional shall confirm that the existing structural steel beams and columns are in compliance with Eq-2 of Section 3.2.8 of this report. Such alterations shall comply with Chapter 34 of the



IBC. For retrofit construction, each side plate shall be configured with an initial opening to permit field-welding access. The cut-out pieces of the side plate may be retained for use as closure plates to close the access window after welding is completed. The existing complete-joint-penetration welds that join beam flanges to column flanges shall be removed. The existing shear tab connecting the web of the beam(s) to the column may be left in place. Existing continuity plates, if any, may be left in place to act as horizontal shear plates.

3.5 Quality Control and Quality Assurance: A quality assurance plan conforming to Sections 1704.2.5.1 and 1705.2 of the 2021, 2018, and 2015 IBC (Sections 1704.2.5.1 and 1705.2.1 of the 2012 IBC) shall be included in the structural design by the registered design professional employed by SidePlate Systems, Inc. and approved by the building official.

Special inspections and tests, and structural observations shall meet the applicable requirements in Chapter 17 of the IBC; Chapter N of AISC 360-16 and Chapter J of AISC 341-16 for the 2021, 2018, 2015, and 2012 IBC; provisions within AISC 303-16 and Clause 7 of AWS D1.8-2016 for the 2021, 2018, 2015, and 2012 IBC.

Special inspections shall verify compliance for steel specifications with the following: welder qualification records and continuity records, steel identification (type/grade), protected storage provided for bolts, nuts, washers, and other fastener components welded joint preparations, condition of welding materials, verify welding equipment, compliance of weld filler specifications and identification in conformance with approved WPS and the provisions in AISC 341-16, AISC 360, AWS D1.1 and AWS D1.8.

For structures assigned to Seismic Design Category C, D, E, and F using the SidePlate Connection System, visual inspection and nondestructive testing shall be performed in accordance with Section 1705.14.1.1 of the 2021 IBC, Section 1705.13.1.1 of the 2018, 2015 IBC (Section 1705.12.2 of the 2012 IBC); Clause 4.9 of AWS D1.1:2015; Clause 7 of AWS D1.8:2016 for the 2021, 2018, 2015, and 2012 IBC; Section J4 of AISC 341-16 and Chapter N of AISC 360-16. NDT personnel shall be qualified in accordance with their employer's written practice, which shall meet AWS D1.1 Clause 6.14.6 and AWS D1.8 Clauses 7.2 and 7.2.4.

In addition to the requirements stated above, a visual inspection shall also include the following requirements for Beam Stub and Full-Length Beam Applications (applied only to Field-Welded):

- Visual inspection of the welds in accordance with AWS D1.1, Section 4.9.1 between the full-depth side plates and column flange tips for beam-stub applications.
- Ultrasonic testing (UT) before preparing mechanical test specimens, in accordance with Section 4.9.2 of AWS D1.1 for the link-beam erection method, which

connects a link beam assembly to the beam stubs of two opposite column tree assemblies with field-joint welds.

- Verification of perpendicular alignment between the bottom cover plate and flange of the beam.
- Verification that the center of the bottom erection bolt is 6 inches (152 mm) above the top of the bottom cover plate.
- Verification that the entire exterior face of the outstanding leg of the vertical shear element (if applicable) is parallel to the web of the beam and that the outside face of the vertical shear element shall not extend beyond the edge of the top cover plate.
- Magnetic particle testing (MT) shall be provided in accordance with AWS D1.1, ASTM E709, ASTM E1444, and Annex G of AWS D1.8:2016 for field fillet welds attaching the cover plates to the side plates. The rate of MT is permitted to be reduced in accordance with Section J6 of AISC 341-16 for the 2021, 2018, 2015, and 2012 IBC.

4.0 PRODUCT DESCRIPTION

4.1 General: The SidePlate Steel Frame Connection System complies with Sections E2, E3, and K1 of AISC 341-16 for the 2021, 2018, 2015, and 2012 IBC. The SidePlate Steel Frame Connection Technology is permitted for use in special moment frame (SMF) or intermediate moment frame (IMF) beam-to-column connections.

4.2 Materials:

4.2.1 Structural Shapes: Rolled wide-flange beams and columns sections shall conform to ASTM A992 or A913 Grade 50, 60, 65, or 70 or A588 and hollow structural sections (HSS) shall conform to ASTM A500 Grade B or C, or ASTM A1085. The limiting width-to-thickness ratio for walls of rectangular HSS Sections is permitted to conform to provisions in Section 3.2.6, Item (6) of this report. Charpy V-Notch (CVN) for hot-rolled shapes with flanges 1½ inches (38 mm) thick and thicker shall conform to Section A3.3 of AISC 341-16. Plates for built-up wide-flange and box shapes shall conform to Section 4.2.2 of this report.

4.2.2 Plates: All connection steel plates, which consist of side plates, cover plates, horizontal shear plates, and vertical shear elements (if applicable), shall be fabricated from structural steel complying with ASTM A572/A572M Grade 50 or A588 steel. The plates used for the vertical shear element (if applicable), which may consist of angles and plates, or bent plates may be fabricated using carbon structural steel complying with ASTM A36/A36M. Plates that are thicker than 2 in. (50 mm) shall have a minimum Charpy V-notch toughness of 20 ft-lb (27 J) at 70 °F (21 °C) in accordance with Section A3.3 of AISC 341-16 for the 2021, 2018, 2015, and 2012 IBC.

4.2.3 Welds: All welding shall be performed using E70 electrodes. The weld filler metal and associated welding



process for all fillet welds shall meet the requirements of any of the following:

- E70T-6, E71T-8, or E70TG-K2 for flux-cored arc welding (FCAW)
- E7XT-9 for flux cored arc welding (FCAW) with gas shielding
- F7A2-EXXX for submerged arc welding (SAW)
- E7018 stick electrode for shielded metal arc welding (SMAW)
- ER70S-X, E70C-XM, or E70C-XC for gas metal arc welding (GMAW), except short circuit transfer

All weld filler metal shall satisfy the requirements specified in Clause 6.3 of the Structural Welding Code-Seismic Supplement (AWS D1.8/D1.8M) including the minimum Charpy V-notch (CV) toughness 20 ft-lb (27 J) at a temperature lower than 0 F (-18 C) as indicated in Section A3.4 of AISC 341-16 for the 2021, 2018, 2015, and 2012 IBC.

4.2.4 Bolts: Bolts shall be pretensioned high-strength bolts conforming to ASTM F3125 Grade A490 or A490M or ASTM F2280 or ASTM F3148 (TnA). Bolt diameter is limited to a maximum of 1½ in. (38 mm). Bolt holes shall be made by drilling, thermally cutting, punching or sub-punching and reaming. Other methods require SidePlate's approval.

5.0 IDENTIFICATION

A notice of intellectual property shall be affixed on each sheet of shop detail and field erection drawings containing the SidePlate Connection System. Such notice shall be provided to the fabrication subcontractor's detailer by SidePlate Systems, Inc. in a format suitable to the needs of the fabricator's detailer.

Identification of structural steel elements containing the SidePlate Connection System shall be in accordance with the 2021 and 2018 IBC Section 2202 (2015 and 2012 IBC Section 2203).

The SidePlate Steel Frame Connection Technology described in Section 4.0 of this report is packaged with a SidePlate patent label identifying the Manufacturer's Name (SidePlate Systems, Inc.), and the Evaluation Report Number (ER-525) to identify the SidePlate Steel Frame Connection System.

6.0 SUBSTANTIATING DATA

6.1 Data in accordance with the ICC-ES Acceptance Criteria for Steel Moment Frame Connection Systems (AC129), approved May 2018, editorially revised February 2021.

6.2 Test reports are from laboratories in compliance with ISO/IEC 17025.

7.0 STATEMENT OF RECOGNITION

This evaluation report describes the results of research completed by IAPMO Uniform Evaluation Service on SidePlate Steel Frame Connection Technology to assess its conformance to the codes and standards shown in Section 1.0 of this report and documents the product's certification.

For additional information about this evaluation report please visit www.uniform-es.org or email at info@uniform-es.org

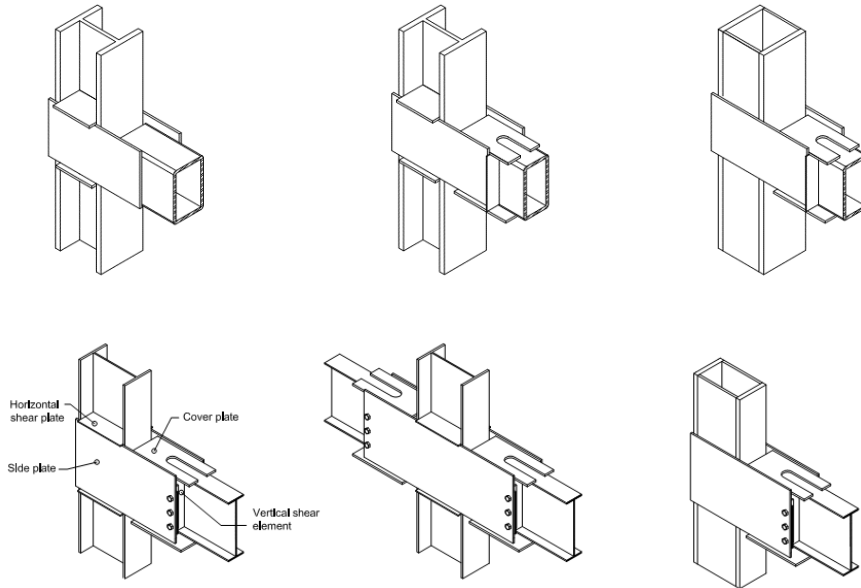

FIGURE 1 – SidePlate Assembled Uniaxial Field-Welded Configurations

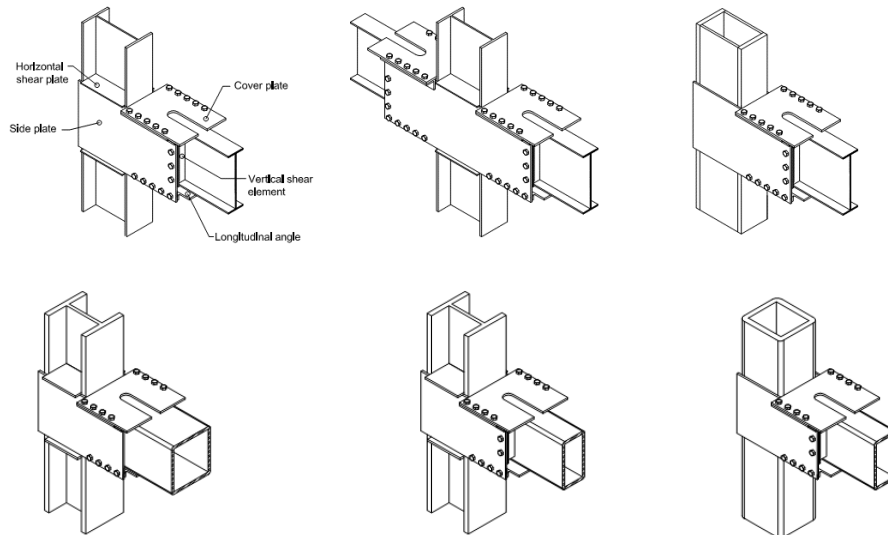

FIGURE 2 – SidePlate Assembled Uniaxial Field-Bolted Standard Configurations

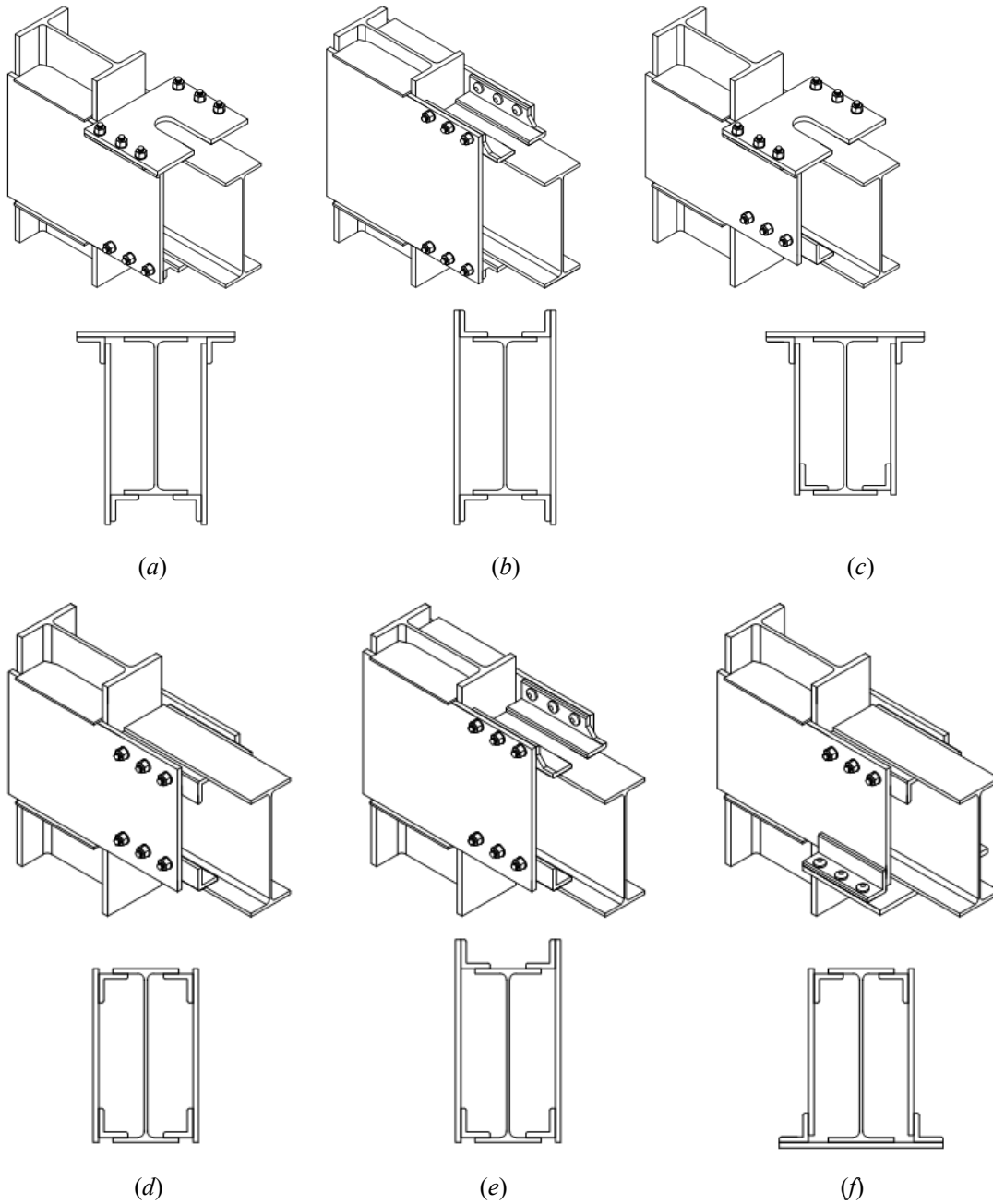

FIGURE 3 – SidePlate field-bolted connection configurations:
(a) a typical field-bolted Standard connection (Configuration A);
(b) a typical field-bolted Narrow connection (Configuration B);
(d)-(f) different variations of Tuck connection (Configuration C)

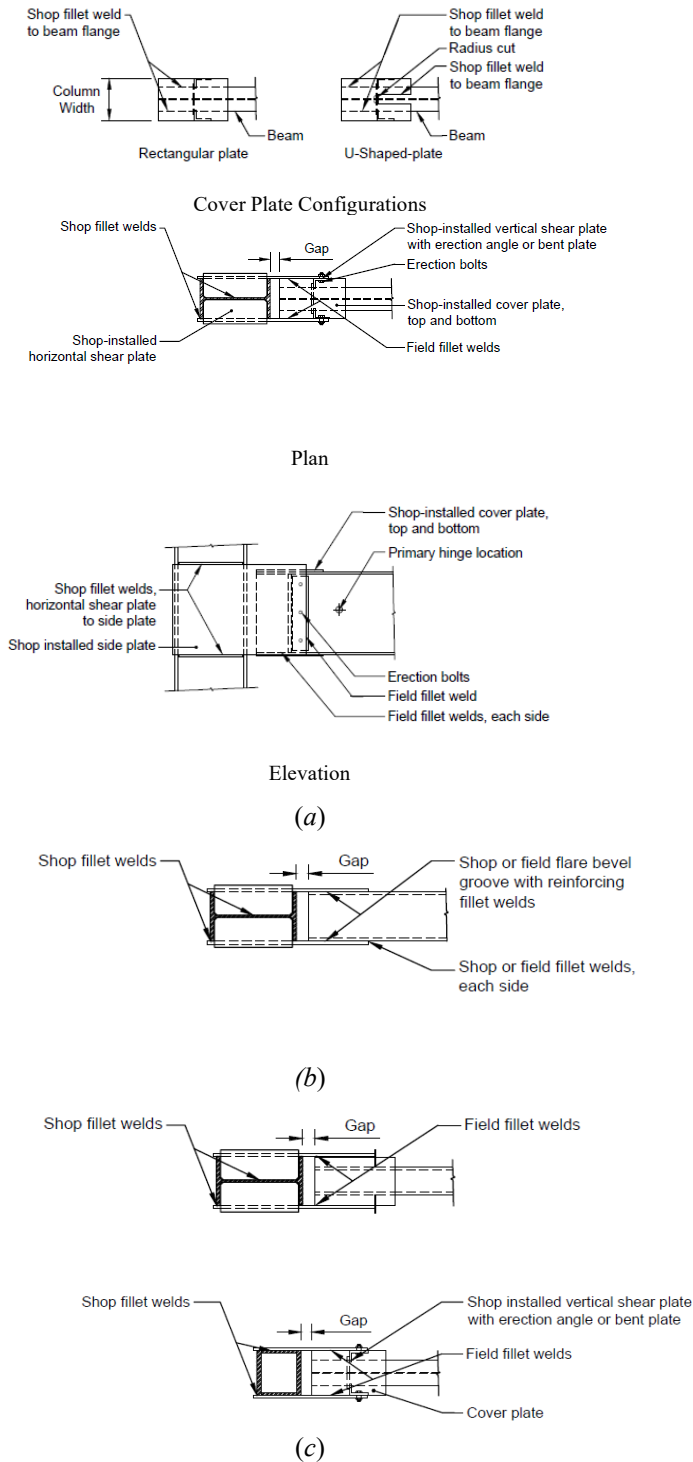

FIGURE 4 - SidePlate Uniaxial Configuration Geometry and Major Components

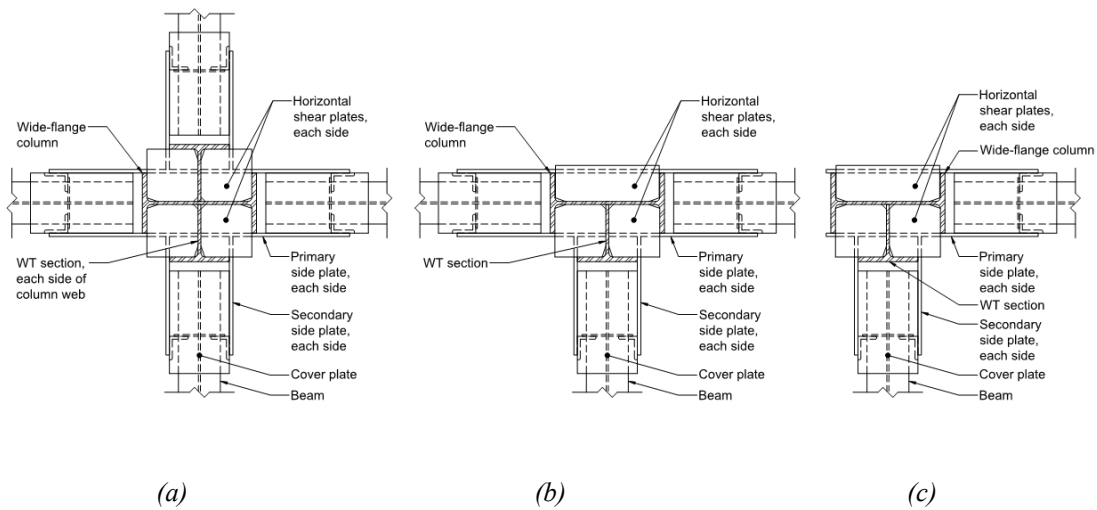

FIGURE 5 - SidePlate Built-up Flanged Cruciform Biaxial Connection in Plan View:
(a) Four sided; (b) Three sided and (c) Two sided (corner)

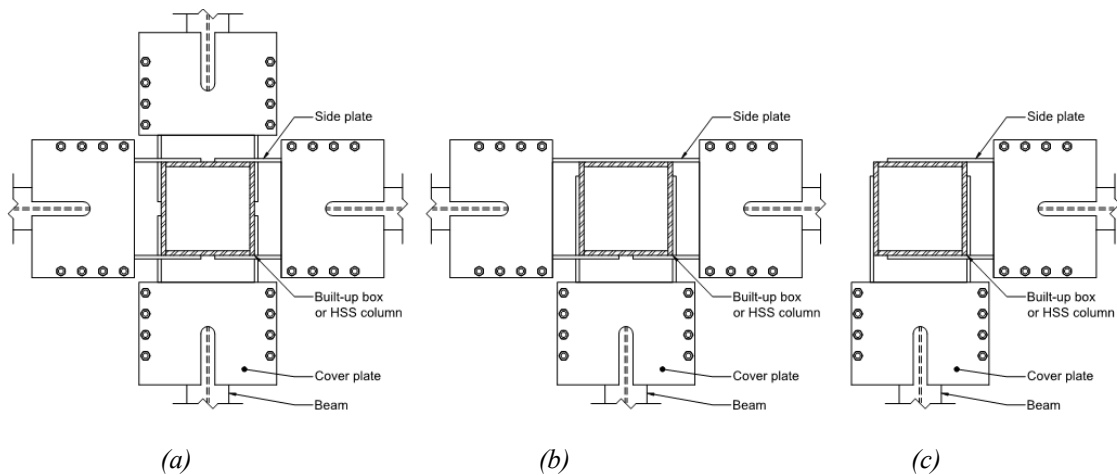

FIGURE 6 - SidePlate Built-up Box/HSS Biaxial Connection in Plan View:
(a) Four sided; (b) Three sided and (c) Two sided (corner)

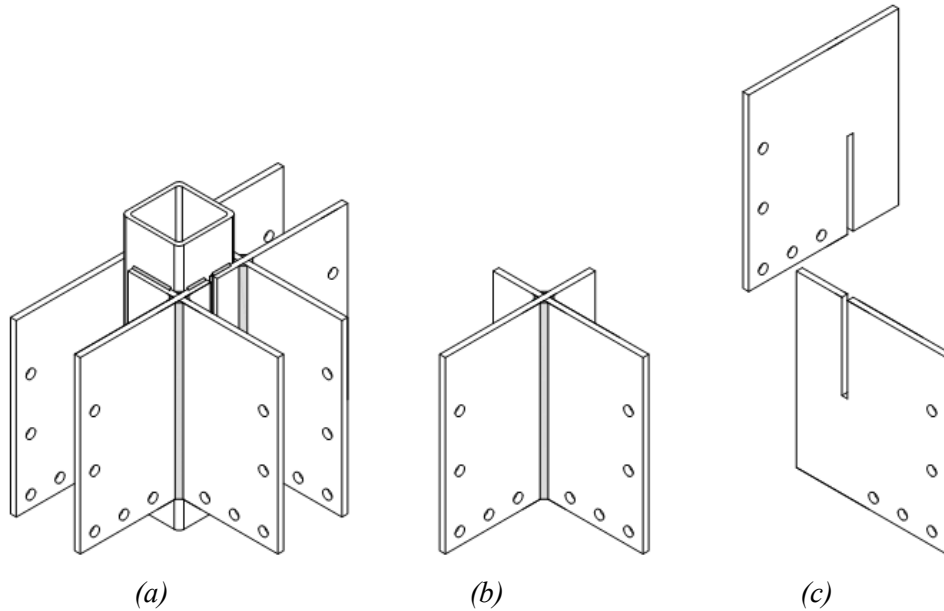

FIGURE 7 - SidePlate Built-up Box/HSS Biaxial Connection:
(a) Isometric view; (b) Plus plates assembly and (c) Slotted side plates

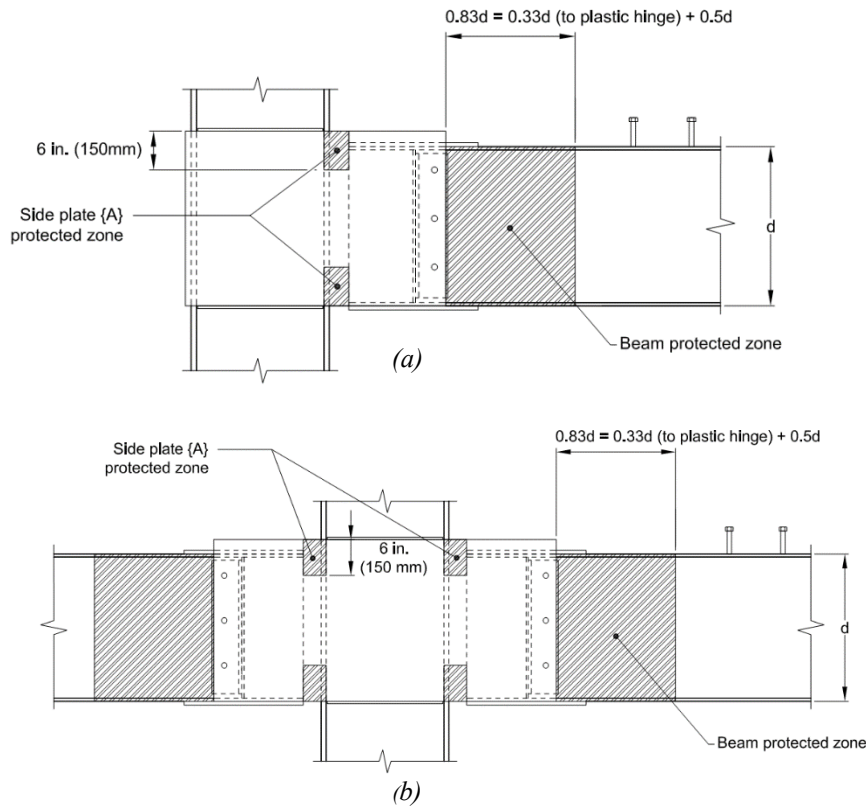
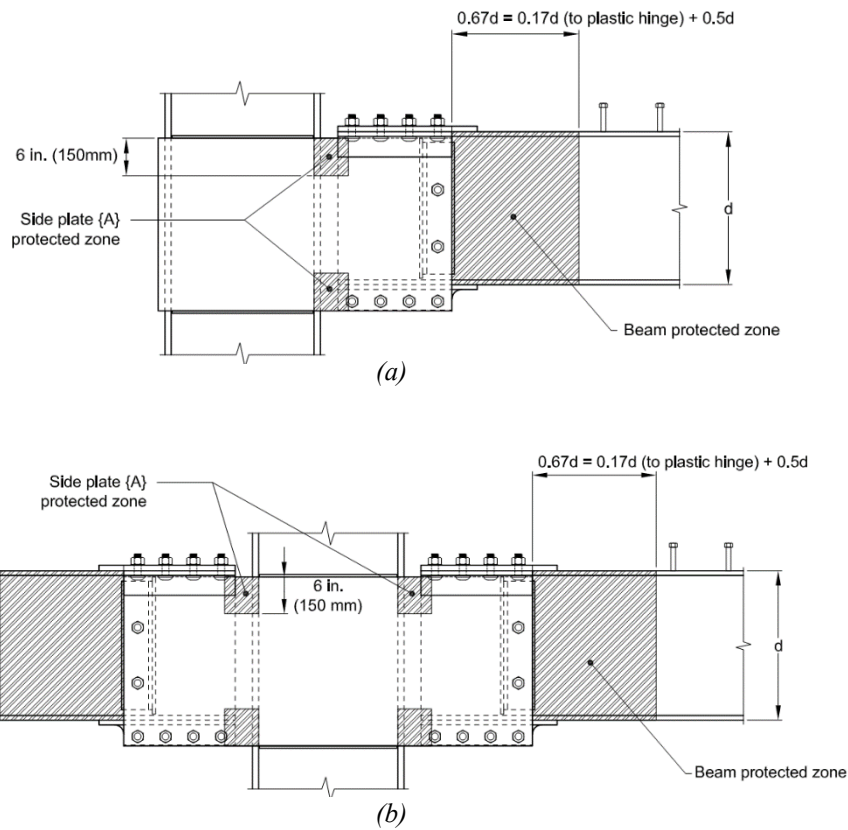
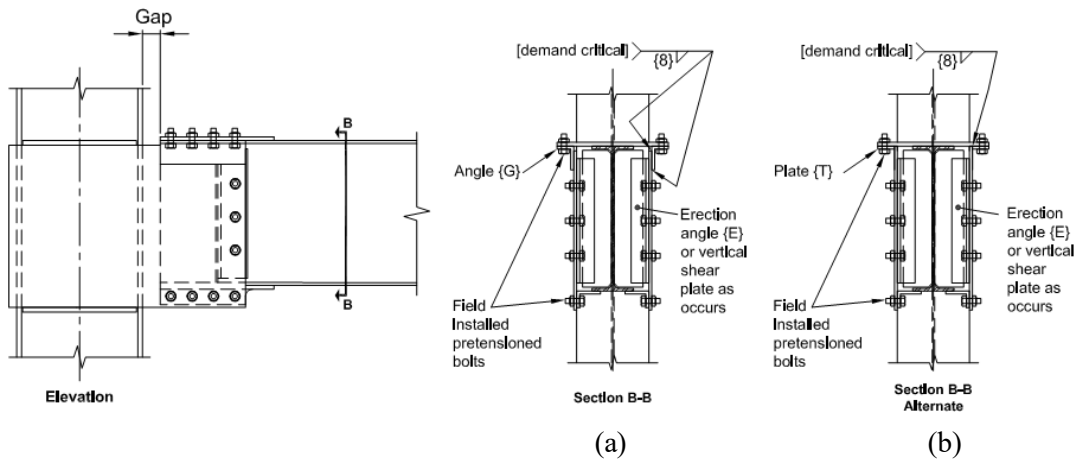

FIGURE 8 - Location of beam and side plate protected zones for the field-welded connection:
(a) one-sided connection; (b) two-sided connection



**FIGURE 9 - Location of beam protected zone for the field-bolted connection:
(a) one-sided connection; (b) two-sided connection**



**FIGURE 10 - Beam-to-side plate field erection detail.
(a) Section B-B, field-bolted Standard configuration;
(b) Alternate section B-B, field-bolted Standard configuration with plate {T}**



CALIFORNIA SUPPLEMENT

SIDEPLATE SYSTEMS, INC.

25909 Pala, Suite 200

Mission Viejo, CA 92691

949-238-8900

www.sideplate.com

SIDEPLATE STEEL FRAME CONNECTION TECHNOLOGY: FIELD-WELDED AND FIELD-BOLTED CONNECTIONS

CSI Section:

05 12 00 Structural Steel Framing

1.0 RECOGNITION

SidePlate Steel Frame Connection Technology described in ER-0525 and this supplemental report has been evaluated for use as beam-to-column connections with Special Moment Frames (SMF) and Intermediate Moment Frames (IMF) in uniaxial and biaxial conditions. SidePlate Steel Frame Connection Technology has been evaluated for structural performance properties, subject to the requirements in ER-525 and this supplemental report. SidePlate Steel Frame Connection systems were evaluated for compliance with the following codes and regulations:

- 2022 and 2019 California Building Code (CBC)

2.0 LIMITATIONS

Use of the SidePlate Steel Frame Connection Technology recognized in this supplement is subject to the following limitations:

2.1 The SidePlate Steel Frame Connection Technology shall comply with the provisions in IAPMO UES ER-525 applicable to the 2021 IBC for use under the 2022 CBC, or the 2018 IBC for use under the 2019 CBC.

2.2 Calculations and specifications verifying compliance with the SidePlate Steel Frame Connection Technology shall be submitted to the plan check engineer at the time of permit application. SidePlate Moment Connection system shall be prepared by a California-licensed engineer employed by SidePlate Systems, Inc.

2.3 Structural design drawings and specifications, shop drawings, and erection drawings shall comply with Sections 1603 and 1603A of the 2022 and 2019 CBC, Sections A4 and I1 of AISC 341-16, and Section A4 of AISC 360-16.

2.4 Fabrication shall comply with Section 3.3 of IAPMO UES ER-525 and approved construction drawings specified by the SidePlate Systems, Inc. as "SP General Notes", and

shall be either performed on the premises of a fabricator registered and approved by the building official in accordance with Section 1704.2.5.1 of the 2022 and 2019 CBC or as specified in Section 3.1 of IAPMO UES ER-525.

2.5 This supplement expires concurrently with ER-525.

3.0 DESIGN AND INSTALLATION

3.1 The design of the structural steel seismic force-resisting systems shall comply with Chapters 22 or 22A of the 2022 and 2019 CBC, as applicable. The SidePlate moment connection is prequalified for use in Special Moment Frame (SMF) and Intermediate Moment Frame (IMF) systems within the limits stated in Sections 3.2 and 3.3 of this supplement.

3.2 **Beam Limitations:** Beams shall satisfy the following limitations:

- (1) Beams shall be rolled wide flange, hollow structural sections (HSS), or built-up I-shaped beams conforming to the requirements of Section 4.2.1 of this report.
- (2) Rolled and built-up wide-flange beam depth shall be limited to W40 (W1000) and W48(W1200) for the field-welded and field-bolted connections, respectively.
- (3) For SMF and IMF, HSS beam depths shall be limited to HSS14 (HSS356) and HSS16 (HSS 406), respectively.
- (4) Rolled and built-up wide-flange beam weight shall be limited to 302 lb/ft (449 kg/m) and 529 lb/ft (787 kg/m) for the field-welded and field-bolted connections, respectively.
- (5) The ratio of the beam span is the distance between the locations of the plastic hinge to beam depth (L_h/d) shall be limited as follows:
 - (a) For SMF systems, 4.5 and 3.5 or greater for field-welded and field-bolted connections, respectively.
 - (b) For IMF systems, 3 or greater.
- (6) The width-to-thickness ratios for beam flanges and webs shall conform to the limits of Sections E2.5a and E3.5a of AISC 341-16 for the 2022 and 2019 CBC.
- (7) Lateral bracing of beams shall be provided as follows:
 - (a) For SMF systems using the beams described in Section 3.2.5 (1) of this report shall comply with Sections D1.2 and E3.4b of AISC 341-16 for the 2022 and 2019 CBC, where the length of the beam is defined as the distance between the ends of the SidePlate connections and the segment of the beam connected to the side plates shall be considered to be braced. As required by AISC 341-16, no additional lateral bracing is required at or near the plastic hinge.



(b) For IMF systems using the beams described in Section 3.2.5 (1) of this report shall comply with Sections D1.2 and E2.4a of AISC 341-16 for the 2022 and 2019 CBC, where the same lateral bracing provisions apply as for SMF systems.

(8) The protected zone in the beam for the field-welded and field-bolted connections shall consist of the portion of the beam as shown in Figures 8 and 9 of this report, respectively.

3.3 Column Limitations: Columns shall satisfy the following:

- (1) Columns shall be any of the rolled shapes, hollow structural section (HSS), built-up I-shaped sections, and/or flanged cruciform sections consisting of rolled shapes or built-up from plates or built-up box sections conforming to the requirements of Section 4.2.1 of this report. Flange and web plates of built-up box columns may continuously be connected by fillet welds or PJP groove welds along the length of the column.
- (2) The beam shall be connected to the side plates that are connected to the flange tips of the wide-flange or corners of HSS or built-up box columns.
- (3) The rolled shape column depth shall be limited to W44 (W1100). The depth of built-up wide-flange columns shall not exceed that for rolled shapes of 44 inches (1100 mm). Built-up box columns shall not have a width exceeding 36 in. (914 mm).
- (4) There is no limit on column weight per foot.
- (5) There are no additional requirements for column flange thickness.
- (6) Width-to-thickness ratios for the flanges and webs of columns shall conform to the requirements of Sections D1.1, E2.5a (for IMF Systems), and E3.5a (for SMF Systems) of AISC 341-16 for the 2022 and 2019 CBC. Table D1.1 of AISC 341-16 is modified to allow the limiting width-to-thickness ratio for walls of rectangular HSS columns to be computed as follows:

$$b/t \leq 0.87(E/F_y)^{1/2}, \text{ or } 21, \text{ whichever is less.}$$

(7) Lateral bracing of columns for SMF shall conform to the requirements in Section E3.4c of AISC 341-16 for the 2022 and 2019 CBC.

3.4 Fabrication: The SidePlate Connection System components shall be manufactured by an approved fabricator in accordance with Section 1704.2.5.1 of the 2022 and 2019 CBC. To demonstrate the ability to produce sound welds, all welders, welding operators, and tack welders shall be qualified in conformance with AWS D1.1, Section 4, Part C.

Welding shall be performed in accordance with a Welding Procedure Specification (WPS) in accordance with AWS D1.1 and Chapters 17 and 17A of the 2022 and 2019 CBC which shall be prepared for every different welding application including welding position, welding process,

electrode manufacturer, filler metal trade name for the electrode type selected, and other essential variables as defined in AWS D1.1.

3.5 Erection: Erection of the SidePlate Connection System shall be in accordance with Chapter N of AISC 360, AISC 303-16, and Chapters I and J of AISC 341-16 for Chapters 22 or 22A of the 2022 and 2019 CBC, as applicable.

The SidePlate Connection System may be used in new, typical, and traditional construction practices. Additionally, it may be used for retrofitting existing beam-to-column moment connections. The registered design professional shall confirm that the existing structural steel beams and columns comply with Eq-2 of Section 3.2.8 of UES ER-525. Such alterations shall comply with Chapter 34 of the 2022 and 2019 CBC.

3.6 Quality Control and Quality Assurance: A quality assurance plan conforming to Sections 1704.2.5.1 and 1705.2 of the 2022 and 2019 CBC shall be included in the structural design by the registered design professional employed by SidePlate Systems, Inc. and approved by the building official.

Special inspections and tests, and structural observations shall meet the applicable requirements in Chapters 17 and as applicable Chapter 17A of the CBC; Chapter N of AISC 360-16 including provisions in Section 1705A.2.1 of 2022 and 2019 CBC, as applicable, and Chapter J of AISC 341-16 for the 2022 and 2019 CBC; Provisions within AISC 303-16 and Clause 7 of AWS D1.8-2016 for the 2022 and 2019 CBC.

Special inspections shall verify compliance for steel specifications with the following: welder qualification records and continuity records, steel identification (type/grade), protected storage provided for bolts, nuts, washers, and other fastener components welded joint preparations, condition of welding materials, verify welding equipment, compliance of weld filler specifications and identification in conformance with approved WPS and the provisions in AISC 341-16, AISC 360, AWS D1.1 and AWS D1.8.

For structures assigned to Seismic Design Category C, D, E, and F using the SidePlate Connection System, visual inspection and nondestructive testing shall be performed in accordance with Section 1705.13.1.1 of the 2022 and 2019 CBC; Clause 4.9 of AWS D1.1:2015; Clause 7 of AWS D1.8:2016 for the 2022 and 2019 CBC; Section J4 of AISC 341-16 including provisions in Section 1705A.2.1 of the 2022 and 2019 CBC, as applicable; and Chapter N of AISC 360-16. NDT personnel shall be qualified in accordance with their employer's written practice, which shall meet AWS D1.1 Clause 6.14.6 and AWS D1.8 Clauses 7.2 and 7.2.4.

In addition to the requirements stated above, visual inspections shall also include the following requirements for Beam Stub and Full-Length Beam Applications (applied only to Field-Welded):



- Visual inspection of the welds in accordance with AWS D1.1, Section 4.9.1 between the full-depth side plates and column flange tips for beam-stub applications.
- Ultrasonic testing (UT) before preparing mechanical test specimens, in accordance with Section 4.9.2 of AWS D1.1 for the link-beam erection method, which connects a link beam assembly to the beam stubs of two opposite column tree assemblies with field-joint welds.
- Verification of perpendicular alignment between the bottom cover plate and flange of the beam.
- Verification that the center of the bottom erection bolt is 6 inches (152 mm) above the top of the bottom cover plate.
- Verification that the entire exterior face of the outstanding leg of the vertical shear element (if applicable) is parallel to the web of the beam and that the outside face of the vertical shear element shall not extend beyond the edge of the top cover plate.
- Magnetic particle testing (MT) shall be provided in accordance with AWS D1.1, ASTM E709, ASTM E1444, and Annex G of AWS D1.8:2016 for field fillet welds attaching the cover plates to the side plates. The rate of MT is permitted to be reduced in accordance with Section J6 of AISC 341-16 for Section 1705A.2.1 of the 2022 and 2019 CBC, as applicable.

For additional information about this evaluation report please visit www.uniform-es.org or email at info@uniform-es.org



CITY OF LOS ANGELES SUPPLEMENT

SIDEPLATE SYSTEMS, INC.
25909 Pala, Suite 200
Mission Viejo, CA 92691
949-238-8900
www.sideplate.com

SIDEPLATE STEEL FRAME CONNECTION TECHNOLOGY: FIELD-WELDED AND FIELD-BOLTED CONNECTIONS

CSI Sections:

05 12 00 Structural Steel Framing

1.0 RECOGNITION

SidePlate Steel Frame Connection Technology described in ER-525, the California Supplement to ER-525, and this supplemental report has been evaluated for use as beam-to-column connections with Special Moment Frames (SMF) and Intermediate Moment Frames (IMF) in uniaxial and biaxial arrangements. SidePlate Steel Frame Connection Technology has been evaluated for structural performance properties, subject to the requirements in ER-525, the California Supplement to ER-525, and this supplemental report. SidePlate Steel Frame Connection systems were evaluated for compliance with the following codes and regulations:

- 2023 and 2020 City of Los Angeles Building Code (LABC)

2.0 LIMITATIONS

Use of the SidePlate Steel Frame Connection Technology recognized in this supplement is subject to the following limitations:

2.1 The SidePlate Steel Frame Connection Technology shall comply with the provisions in IAPMO UES ER-525 and California supplement applicable to the 2022 CBC for use under the 2023 LABC or 2019 CBC for use under the 2020 LABC.

2.2 Calculations and specifications verifying compliance with the SidePlate Steel Frame Connection Technology shall be submitted to the plan check engineer at the time of permit application. SidePlate Moment Connection system shall be prepared by a California-licensed engineer employed by SidePlate Systems, Inc.

2.3 Continuous inspection shall be provided by The Register Deputy Inspector in accordance with Sections 1704 and 1705 of the 2023 and 2020 City of Los Angeles Building Code during installation of the SidePlate Steel Frame Connection Technology.

2.4 Special inspections and tests, and structural observations shall meet the applicable requirements in Chapter 17 of the LABC, Chapter N of AISC 360-16, Chapter J of AISC 341-16, and provisions within AISC 303-16 and Clause 7 of AWS D1.8-2016.

2.5 Fabrication of SidePlate Steel Frame Connection Technology used within LA City shall be performed in the shop of a licensed fabricator by the City of Los Angeles Building Department.

2.6 This supplement expires concurrently with ER-525.

For additional information about this evaluation report please visit www.uniform-es.org or email at info@uniform-es.org