



SIMPSON STRONG-TIE COMPANY INC.
5956 West Las Positas Boulevard
Pleasanton, California 94588
(800) 925-5099
www.strongtie.com

SIMPSON STRONG-TIE NAIL HOLD-DOWNS (TENSION TIES)

CSI Division:
06—WOOD, PLASTICS, AND COMPOSITES
CSI Section:
06 05 23—Wood, Plastic, and Composite Fastenings

1.0 SCOPE OF EVALUATION

1.1 Compliance to the following codes & regulations:

- 2021 International Building Code® (IBC)
- 2021 International Residential Code® (IRC)
- 2018 International Building Code® (IBC)
- 2018 International Residential Code® (IRC)
- 2015 International Building Code® (IBC)
- 2015 International Residential Code® (IRC)
- 2012 International Building Code® (IBC)
- 2012 International Residential Code® (IRC)
- 2009 International Building Code® (IBC)
- 2009 International Residential Code® (IRC)
- 2020 City of Los Angeles Building Code (LABC) – attached Supplement
- 2020 City of Los Angeles Residential Code (LARC) – attached Supplement

1.2 Evaluated in accordance with:

- ICC-ES AC155

1.3 Properties assessed:

- Structural

2.0 PRODUCT USE

Simpson Strong-Tie structural nail hold-down connectors (tension ties) are used as wood framing anchorage, such as to connect wood posts to concrete foundations or to connect an upper-story wood post to a lower-story supporting wood post, in accordance with 2021 IBC Sections [2304.10.4](#), [2305.1](#), [2305.3](#), [2308.6.5.1](#) and [2308.6.5.2](#); 2018 and 2015 IBC Sections [2304.10.3](#), [2305.1](#), [2305.3](#), [2308.6.5.1](#) and [2308.6.5.2](#); 2012 and 2009 IBC Sections [2304.9.3](#), [2305.1](#), [2305.3](#), [2308.9.3.1](#), [2308.9.3.2](#) and [AWC SDPWS—2021 Section 4.3.6.4.2](#), [AWC SDPWS—2018](#), [AWC SDPWS—2015 or AF&PA SDPWS-2008](#), Special Design Provisions for Wind and Seismic Sections [4.3.6.4.2](#) and [4.3.6.1.2](#), and as anchorage of concrete and masonry walls to structural wood

elements to provide lateral support for the walls as required by IBC Section [1604.8](#).

When regulated under the IRC, the hold-down connectors may also be used when an engineered design is submitted in accordance with IRC Section [R301.1.3](#).

Hold-down connectors may be used for anchoring concrete and masonry walls to structural wood elements and provide lateral support for the walls in accordance with 2021, 2018, and 2015 IRC Sections [R606.12.2.3](#) and [R608.9.1](#); 2012 and 2009 IRC Sections [R606.12.2.3](#) and [R611.9.1](#).

The DTT1 Hold-Down may be used to satisfy the deck lateral load connection requirement of a minimum of 750 pounds (3336 N) hold-down tension device set forth in 2021 and 2018 IRC Section [R507.9.2](#) and 2015 IRC Section [R507.2.4](#) for installations conforming to 2021 and 2018 IRC Figure [R507.9.2\(2\)](#) and 2015 IRC Figure [R507.2.3\(2\)](#), respectively.

3.0 PRODUCT DESCRIPTION

3.1 Product information

3.1.1 LTT Nail Hold-downs: LTT Light Tension Ties are nailed hold-downs consisting of a steel strap component with 90-degree angle bend at the end and a base plate component installed in the bend, which eliminates the need for a washer to transfer load. These hold-downs have pre-punched holes for the installation of fasteners used to connect the hold-down to the wood member. Bodies of the LTT19, LTT20B, and LTTI31 are formed from No.16, No.12 and No.18 gage galvanized steel respectively. The base plate component for LTT's is No. 3 gage galvanized steel. LTTTP2 is a single-piece nailed hold-down for resisting tension loads. LTTTP2 is formed from No. 10 gage galvanized steel. [Figure 1](#) and [Table 1](#) of this report provide product dimensions, required fasteners, and ASD allowable loads.

3.1.2 HTT Nail Hold-downs: HTT Heavy Tension Ties are single-piece formed nail hold-downs consisting of a steel strap with a four-ply formed seat element for an anchor bolt. The straight-strap portion has pre-punched holes for the installation of fasteners used to connect the hold-down to the wood member. HTT is die-formed from No. 11 gage galvanized steel. Bearing plate BP5/8-2 is fabricated from 3/16 inch thickness steel and may be installed with HTT5 as a load transfer washer for additional capacity. [Figure 2](#) and [Table 1](#) of this report provide product dimensions, required fasteners and ASD allowable loads.

The product described in this Uniform Evaluation Service (UES) Report has been evaluated as an alternative material, design or method of construction in order to satisfy and comply with the intent of the provision of the code, as noted in this report, and for at least equivalence to that prescribed in the code in quality, strength, effectiveness, fire resistance, durability and safety, as applicable, in accordance with IBC Section 104.11. This document shall only be reproduced in its entirety.





3.1.3 DTT1 Nail Hold-down: The DTT1 hold-down consists of a single-piece formed structural steel component with pre-punched holes for the installation of fasteners used to connect the hold-down to the wood member. The DTT1 is formed from No. 14 gage galvanized steel.

The DTT1 may be used to anchor to the supporting structure using a 3/8-inch (9.5 mm) diameter machine bolt, anchor bolt, lag screw, or a 0.277-inch (7.0 mm) diameter Strong-Drive SDWH TIMBER-HEX HDG screw. A 3/8-inch (9.5 mm) standard cut washer is required when using a machine bolt, anchor bolt, or lag screw. SDWH screws are manufactured with an integral washer and do not require a washer.

One steel, plain (flat), standard plate (W) washer conforming to [ASTM F844](#) and [ASME B18.22.1](#), Type A, with a 7/16-inch (11.1 mm) inner diameter, and a 1-inch (25.4 mm) outer diameter shall be installed between the nut and the seat of the DTT1 hold-down where required. The standard plate washer dimension tolerances shall be in accordance with ASTM B18.22.1. [Figure 3](#) and [Table 2](#) of this report contain product dimensions, required fasteners, and allowable loads.

3.2 Material information

3.2.1 Steel: LTT and HTT nail hold-downs described in this report are manufactured from [ASTM A653](#) SS Grade 33 galvanized steel with a minimum yield strength (F_y) of 33,000 psi (227 MPa) and a minimum ultimate tensile strength (F_u) of 45,000 psi (310 MPa). Load transfer base plates of the LTT19, LTT20B, LTTI31, and bearing plate BP5/8-2 are fabricated from [ASTM A1011](#) SS Grade 33 steel having a minimum yield strength of 33,000 psi (227 MPa) and a minimum ultimate strength of 52,000 psi (359 MPa). Base metal thicknesses for the tension ties in this report are as follows:

THICKNESS (GAGE)	BASE METAL THICKNESS (inches)
3/16 inch	0.1775
No. 3	0.2285
No. 10	0.1275
No. 11	0.1105
No. 12	0.0975
No. 14	0.0721
No. 16	0.0555
No. 18	0.0445

For SI: 1 inch = 25.4 mm

Hold-downs have a minimum G90 zinc coating specification in accordance with ASTM A653. Some models may also be available with either a G185 zinc coating (denoted by model numbers ending in the letter Z) or with a batch hot-dipped

galvanized coating with a minimum specified coating weight of 2.0 ounces of zinc per square foot of surface area (600 g/m²) total for both sides in accordance with [ASTM A123](#) (denoted by model numbers ending with the letters HDG). Model numbers in this report do not list the Z or HDG ending but the information shown applies. The lumber treater or holder of this report (Simpson Strong-Tie) shall be contacted for recommendations on minimum corrosion resistance of steel connectors in contact with the specific proprietary preservative-treated or fire-retardant-treated lumber.

3.2.2 Wood: Wood members connected to hold-downs shall be either sawn lumber or engineered lumber. Sawn lumber shall have a minimum specific gravity of 0.50 and a maximum moisture content of 19 percent. Engineered lumber shall have a minimum equivalent specific gravity of 0.50 and a maximum moisture content of 16 percent. The minimum thicknesses (depth) of the wood members in the direction of the fastener penetration are shown in [Table 1](#) of this report and the required minimum width of the wood members is 3 1/2 inches (89 mm), except as noted.

3.2.3 Fasteners

3.2.3.1 Nails: Common nails used with connectors in this report shall comply with [ASTM F1667](#) and have the following minimum fastener dimensions and bending yield strengths (F_{yb}):

NAIL SIZE	SHANK DIAMETER (inches)	FASTENER LENGTH (inches)	F_{yb} (psi)
10d x 1 1/2	0.148	1 1/2	90,000
10d x 2 1/2	0.148	2 1/2	90,000
10d	0.148	3	90,000
16d x 2 1/2	0.162	2 1/2	90,000
16d	0.162	3 1/2	90,000

For SI: 1 inch = 25.4 mm, 1 psi = 6.895 kPa

3.2.3.2 Bolts: Machine bolts shall comply with [ASME Standard B18.2.1](#) and with [ASTM A307](#). The minimum bending yield strength (F_{yb}) of the bolt shall be 45,000 psi (310 MPa).

3.2.3.3 Threaded Anchor Rods: As a minimum, threaded steel anchor rods shall comply with [ASTM F1554](#) Grade 36.

3.2.3.4 Preservative-treated and fire-retardant-treated wood: Fasteners used in contact with preservative-treated or fire-retardant-treated lumber shall comply with 2021 IBC Section [2304.10.6](#), 2018 and 2015 IBC Section [2304.10.5](#), 2012 and 2009, IBC Section [2304.9.5](#), 2021, 2018, 2015, 2012, and 2009 IRC Section [R317.3](#), as applicable. The lumber treater or report holder shall be contacted for recommendations on minimum corrosion resistance and connection capacities of fasteners used with the specific



proprietary preservative-treated or fire-retardant-treated lumber.

3.2.3.5 Screws: The LTTTP2 and HTT5-3/4 Hold-down may be attached to wood members with SD Series screws. The ICC-ES [ESR-3046](#) shall be referenced with respect to minimum requirements for installation, exposure, and contact with preservative-treated or fire-retardant-treated lumber.

Strong-Drive SDWH TIMBER-HEX HDG screw with an integral washer may be used to anchor the DTT1 to a supporting wood member in accordance with IAPMO UES [ER-192](#).

Lag screws may be used to anchor the DTT1 to a supporting wood member. Lag screws shall be 3/8 inch (9.5 mm) diameter and comply with [ANSI/ASME Standard B18.6.1](#).

4.0 DESIGN AND INSTALLATION

4.1 Design

4.1.1 Hold-Down Assembly: Allowable loads shown in [Table 1](#) of this report are for hold-down assemblies consisting of the following components: (1) hold-down device; (2) an anchor bolt/rod attached to the seat of the device; (3) a wood member having minimum specified dimensions and properties; (4) quantity and size of fasteners used to attach the hold-down device to the wood member; and, in some cases as noted (5) bearing plates or washers. Allowable loads shown in the product tables of this report are based on allowable stress design (ASD) and include the load duration factor (C_D) corresponding with the applicable loads in accordance with the ANSI/AWC [NDS-2018](#) ANSI/AWC [NDS-2015](#) or [-2012](#) or ANSI/AF&PA [NDS-2005](#), National Design Specification for Wood Construction. The assembly shall have an allowable strength equal to or exceeding the required strength of the assembly under the action of the ASD (Allowable Stress Design) load combinations referenced in the applicable code.

Where design load combinations include earthquake loads or effects, story drifts of the structure shall be determined in accordance with Section 12.8.6 of [ASCE 7](#) (ASCE 7-16 for 2021 and 2018 IBC) (ASCE 7-10 for 2015 and 2012 IBC) (ASCE 7-05 for 2009 IBC) except for those structures analyzed using the Simplified Design Procedure pursuant to Section 12.14.

Deflection of a shear wall restrained from overturning by hold-downs installed in accordance with this report shall be determined in accordance with 2021, 2018, 2015, and 2012 IBC Section 2305.3, 2009 IBC Section [2305.1](#). Total deflection values, Δ_{all} and Δ_s , at ASD-level and strength-level forces, respectively, for hold-down assemblies shown in [Table 1](#) of this report, include all sources of hold-down device

extension and rotation and anchor rod elongation where the length of the anchor rod is a maximum of 4½ inches (152 mm). The contribution of the hold-down anchor rod elongation to the total elongation (deflection) of the hold-down assembly needs to be considered when the actual diameter, length, or ASTM steel specification of the anchor rod differs from that described in this report.

Design of hold-downs used in series shall account for the cumulative deformation of all hold-downs (tie-downs) within said series.

Symbol Δ_s as used in this report refers to the symbol d_a in IBC Section 2305.3 and the symbol Δ_a in [AWC SDPWS—2021 or -2015](#), or [ANSI/AF&PA SDPWS-2008](#) or [-2005](#) Section 4.3.2.

When hold-downs are fastened to wood having a moisture content greater than 19 percent for sawn lumber or 16 percent for engineered lumber, or where wet service is expected, allowable loads shown in [Table 1](#) of this report shall be adjusted by the wet service factor (C_m) specified in the ANSI/AWC NDS-2018, ANSI/AWC NDS-2015 or 2012 or ANSI/AF&PA NDS-2005.

Tabulated allowable loads are for hold-downs connected to wood used under continuously dry interior conditions and where sustained temperatures are 100°F (37.8°C) or less.

When hold-downs are fastened to wood that will experience sustained exposure to temperatures exceeding 100°F (37.8°C), allowable loads shown in [Table 1](#) of this report shall be adjusted by the temperature factor (C_t) specified in the ANSI/AWC NDS-2018, -2015 or -2012 or ANSI/AF&PA NDS-2005.

The design of wood members fastened to the LTT and HTT hold-down (tie-down) device(s) shall consider combined stresses as follows:

Single shear: The wood member shall be checked for its allowable capacity at the critical net section for total combined stresses in accordance with the NDS, where applicable. Total combined stresses at the critical net section shall consider combined flexural bending due to hold-down (tie-down) eccentricity relative to the centroid of the connected wood member (M_{xx} and M_{yy}), and tension (T).

4.1.2 Anchorage to Concrete or Masonry: Design of anchorage to concrete or masonry structural members shall be determined by a structural design professional in accordance with [Chapters 19](#) or [21](#) of the IBC, as applicable. The design shall address adequate embedment length and anchorage details, including edge and end distances.



4.2 Installation: Installation of the Simpson Strong-Tie hold-down connectors shall be in accordance with this evaluation report and the manufacturer's published installation instructions. In the event of a conflict between this report and the manufacturer's published installation instructions, the more restrictive governs.

4.3 Special Inspection

4.3.1 IBC: A statement of special inspection shall be prepared by the registered design professional in responsible charge and submitted to the building official for approval when required by 2021, 2018, 2015, and 2012 IBC Section [1704.3](#) or 2009 IBC Section [1705](#). Structural observations shall be provided where required in 2021, 2018, and 2015 IBC Section 1704.6, or 2012 IBC Section 1704.5. A statement of responsibility shall be submitted by each responsible contractor to the building official for approval when required by 2021, 2018, 2015, and 2012 IBC Section [1704.4](#), 2009 IBC Section [1709](#).

4.3.2 Periodic special inspection shall be conducted when the hold-downs are components within the main wind-force-resisting system of structures constructed in areas listed in 2021 IBC Section [1705.12](#), 2018, 2015 IBC Section [1705.11](#), 2012 IBC Section [1705.10](#), 2009 IBC Section [1706.1](#). Special inspection requirements do not apply to structures, or portions thereof, that qualify for an exception pursuant to 2021 IBC Section [1704.2](#), or [1705.12.1](#), 2018 and 2015 IBC Sections [1704.2](#) or [1705.11.1](#), 2012 IBC Sections [1704.2](#), or [1705.10.1](#), 2009 IBC Sections [1704.1](#), [1704.4](#), [1706.2](#) or [1706.3](#).

4.3.3 Periodic special inspection for seismic resistance shall be conducted in accordance with 2021 IBC Section [1705.13](#), 2018, 2015 IBC Section 1705.12, 2012 IBC Section 1705.11 or 2009 Section [1707](#) where required. Special inspection requirements for seismic resistance do not apply to structures, or portions thereof, that qualify for an exception pursuant to 2021 IBC Sections 1704.2 and 1705.13, 2018 and 2015 IBC Sections 1704.2 and [1705.12](#), 2012 IBC Sections 1704.2, [1705.11](#), and [1705.11.2](#) or 2009 IBC Sections 1704.1, [1705.3](#), [1707.3](#) or [1707.4](#).

4.3.4 For installations under the IRC, special inspection is not normally required. However, when an engineered design is submitted or required pursuant to 2021, 2018, 2015, 2012, and 2009 IRC Section R301.1.3, periodic special inspection requirements and exemptions are as stated in Sections 4.3.1, 4.3.2, and 4.3.3 of this report, as applicable.

5.0 LIMITATIONS

Simpson Strong-Tie nail hold-down connectors described in this report comply with, or are suitable alternatives to, what

is specified in those codes listed in Section [1.0](#) of this report subject to the following conditions:

5.1 Hold-downs shall be manufactured, identified, and installed in accordance with this report and the manufacturer's published installation instructions. Installation instructions shall be available at the job site at all times during installation. Where conflicts occur, the more restrictive shall govern.

5.2 Calculations, drawings, and design details showing compliance with this report shall be submitted to the building official. The calculations, drawings, and design details shall be prepared by a registered design professional where required by the statutes of the jurisdiction in which the project is to be constructed.

5.3 Adjustment factors noted in Section [4.1](#) of this report and the applicable codes shall be considered where applicable.

5.4 Connected wood members and fasteners shall comply, respectively, with Sections [3.2.2](#) and [3.2.3](#) of this report.

5.5 The use of hold-downs (tie-downs) in contact with chemically treated preservative wood is subject to the approval of the building official, since the effects of corrosion of metal in contact with chemically treated wood on the structural performance of the devices are outside the scope of this report. Section [3.2.1](#) of this report provides additional information. Use of fasteners with preservative-or-fire-retardant-treated lumber shall be in accordance with Section [3.2.3](#) of this report.

5.6 Anchorage to concrete or masonry structural members shall be provided in accordance with Section [4.1.2](#) of this report.

5.7 No further duration of load increase for wind or earthquake loading shall be allowed.

5.8 For compliance with the 2021, 2018, 2015, 2012, or 2009 IBC, a statement of special inspection shall be prepared by the registered design professional in responsible charge, and submitted to the building official for approval, where required by 2021, 2018, 2015 and 2012 IBC Section 1704.3 or Section 1705 of the 2009 IBC.

5.9 Special inspections for seismic or wind resistance shall be conducted as required, and in accordance with the appropriate sections of [Chapter 17](#) of the IBC and Sections 4.3.2 and 4.3.3 of this report.

5.10 Special inspections for anchor bolts in concrete or masonry shall be conducted in accordance with Sections [1705.3](#) or [1705.4](#) of the 2021, 2018, 2015, and 2012 IBC, or Sections 1704.4 or [1704.5](#) of the 2009 IBC.



6.0 SUBSTANTIATING DATA

Data in accordance with ICC-ES Acceptance Criteria for Hold-Downs (Tie-Downs) Attached to Wood Members (AC155), inclusive of tests and calculations. Test reports are from laboratories in compliance with [ISO/IEC 17025](#).

7.0 IDENTIFICATION

Products described in this report are identified with a die-stamped label indicating the name of the manufacturer (Simpson Strong-Tie), the model number, and the number of the index evaluation report ([ER-102](#)) that identifies products recognized in this report.

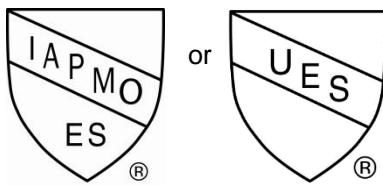

IAPMO UES ER-130

For additional information about this evaluation report please visit www.uniform-es.org or email at info@uniform-es.org



TABLE 1: ALLOWABLE LOADS FOR THE LTT AND HTT NAIL HOLD-DOWNS (TENSION TIES) ASSEMBLIES

MODEL NO.	DIMENSIONS					FASTENERS		MIN. WOOD MEMBER THICKNESS ¹ (inches)	ALLOWABLE TENSION LOADS ^{2,3,4,5} , P _{all} (lbs) C _D = 1.6	DISPLACEMENT Δ AT MAXIMUM LOAD ^{6,7} (in.)		
	W	L	CL	B	SO	ANCH OR BOLT	FASTENER QUANTITY			Δ _{all}	Δ _s	
LTT19 ⁽⁸⁾	1¾	19½	1¾	2¾	5/16	½, 5/8 or ¾	8-10dx1½	3	1310	0.180	0.248	
							8-10d	3	1340	0.157	0.233	
LTT20B ⁽⁸⁾	2	19¾	1½	3⅞	5/16	½, 5/8 or ¾	10-10dx1½	3	1355	0.195	0.250	
							10-10d	3	1500	0.185	0.250	
							2-½" Bolt ⁽⁹⁾	3	1625	0.183	0.250	
LTTI31	3¾	31	1¾	2¾	¼	¾	18-10dx1½	3	1350	0.193	0.250	
LTTTP2	2 9/16	14 15/16	1 ½	2 15/16	7/16	½, 5/8 or ¾	½	12-10dx1½	1½	1680	0.138	0.250
							5/8 or ¾	12-10dx1½	1½	2135	0.112	0.180
							½	12-SD9112	1½	2320	0.112	0.174
							5/8 or ¾	12-SD9112	1½	2570	0.136	0.215
							½, 5/8 or ¾	12-10dx2½	3	2275	0.128	0.250
							½, 5/8 or ¾	15-10dx2½	3½ ⁽¹⁴⁾	1845	0.104	0.141
HTT4	2½	12¾	1¾	2	7/16	¾	18-10dx1½	3	3610	0.086	0.135	
							18-16dx2½ ⁽¹¹⁾	3	4235	0.123	0.201	
HTT5	2½	16	17/16	2	7/16	¾	26-10dx1½	3	4350	0.120	0.209	
							26-10d	3	4670	0.116	0.234	
							26-16dx2½ ⁽¹¹⁾	3	5090 ⁽¹⁰⁾	0.135	0.250	
HTT5KT	2½	16	17/16	2	7/16	¾	26-SD10212	3	5445	0.103	0.190	
HTT5-3/4	2½	16	17/16	2	7/16	¾	26-10dx1½	1½ ⁽¹²⁾	4065	0.103	0.190	
							26-SD10112	1½ ⁽¹³⁾	4830	0.100	0.159	
							26-16dx2½ ⁽¹¹⁾	3	5090	0.121	0.197	

SI: 1 inch = 25.4 mm, 1 lbs = 4.45 N.

1. Tabulated allowable loads are for a hold-down assembly consisting of the hold-down device attached to wood structural with a certain minimum wood thickness, or multiple members attached together as shown in this table (Table 1). The minimum width of the wood members shall be 3½ inches, except as noted. The allowable load values of the hold-down (tie-down) device are a measure of steel strength of the device when tested on a steel jig with a safety factor of 2.5 applied to the (lowest or average, whichever is applicable) maximum test load.
2. Allowable loads for the hold-down assemblies are based on allowable stress design (ASD) and include the load duration factor, C_D = 1.6, corresponding with wind/earthquake loading in accordance with the NDS. No further increase is allowed. Reduce where other load durations govern. The allowable strength values are applicable for designs complying with Sections 12.10 and 12.11.2 of [ASCE 7](#).
3. When using the basic load combinations in accordance with 2021 IBC Section [1605.1](#) (ASCE 7-16 Section 2.4), or 2018 (2015) (2012) (2009) IBC Section [1605.3.1](#), the tabulated allowable loads for the hold-down assembly shall not be increased for wind or earthquake loading. When using the alternative basic load combinations in 2021 IBC Section [1605.2](#), or 2018 (2015) (2012) IBC Section [1605.3.2](#) that includes wind or earthquake loads, the tabulated allowable loads for the hold-down assembly shall not be increased by 33⅓ percent, nor shall the alternative basic load combinations be reduced by a factor of 0.75.
4. Anchorage to concrete or masonry shall be determined in accordance with Section [4.1.2](#) of this report.
5. Tabulated allowable (ASD) tension loads shall be multiplied by 1.4 to obtain the strength-level resistance loads associated with the tabulated Δ_s deformations.
6. Tabulated displacement values, Δ_{all} and Δ_s, for hold-down assemblies include all sources of hold-down assembly elongation, such as fastener slip, hold-down device extension and rotation, and anchor rod elongation, at ASD-level and strength level forces respectively.
7. Elongation of the hold-down anchor rod shall be calculated when the ASTM steel specification of the anchor rod differs from that described in Section 3.2.4 of this report or the actual unbraced length is greater than 4½ inches. In lieu of calculating the elongation of the hold-down anchor rod for hold-



downs raised 4½ to 18 inches above the concrete, it is permitted to add an additional anchor rod elongation of 0.01 inches to the tabulated hold-down deflection.

8. If a ½ or ¾ inch diameter anchor bolt is used for the LTT19, LTT20B or LTTTP2, add a standard cut washer to the seat. No additional washer is required for a ¾ inch diameter anchor bolt. Table 1 provides specified anchor bolt sizes.
9. Wood member bolts shall be in accordance with Section 3.2.3.2 of this report.
10. Allowable tension load for HTT5 with bearing washer BP5/8-2 is 5295 lbs. ($\Delta_{all} = 0.126$, $\Delta_s = 0.179$).
11. 16d common nails are permitted to substitute for 16d \times 2½ inch long nails.
12. The minimum width of the wood structural member shall be 5½ inches (2 \times 6 nominal).
13. The minimum width of the wood structural member shall be 7¼ inches (2 \times 8 nominal).
14. The minimum width of the wood structural member shall be 1½ inches (2 \times 4 nominal).

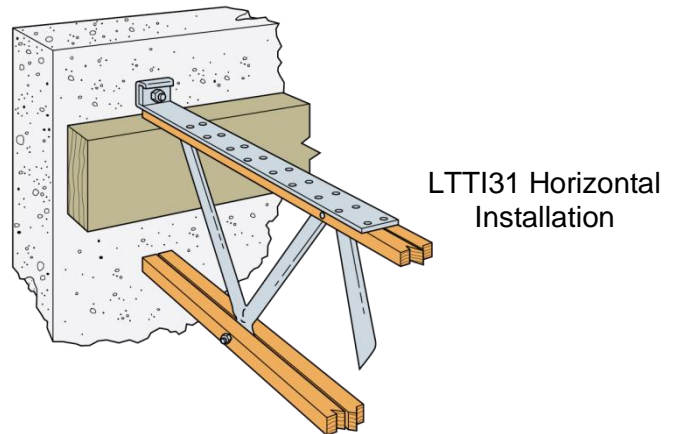
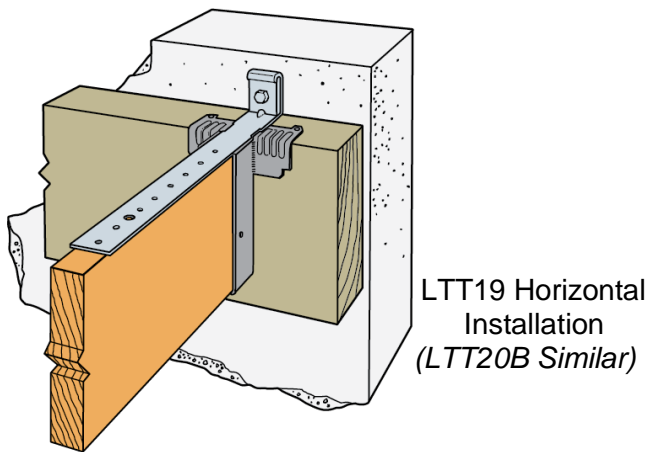
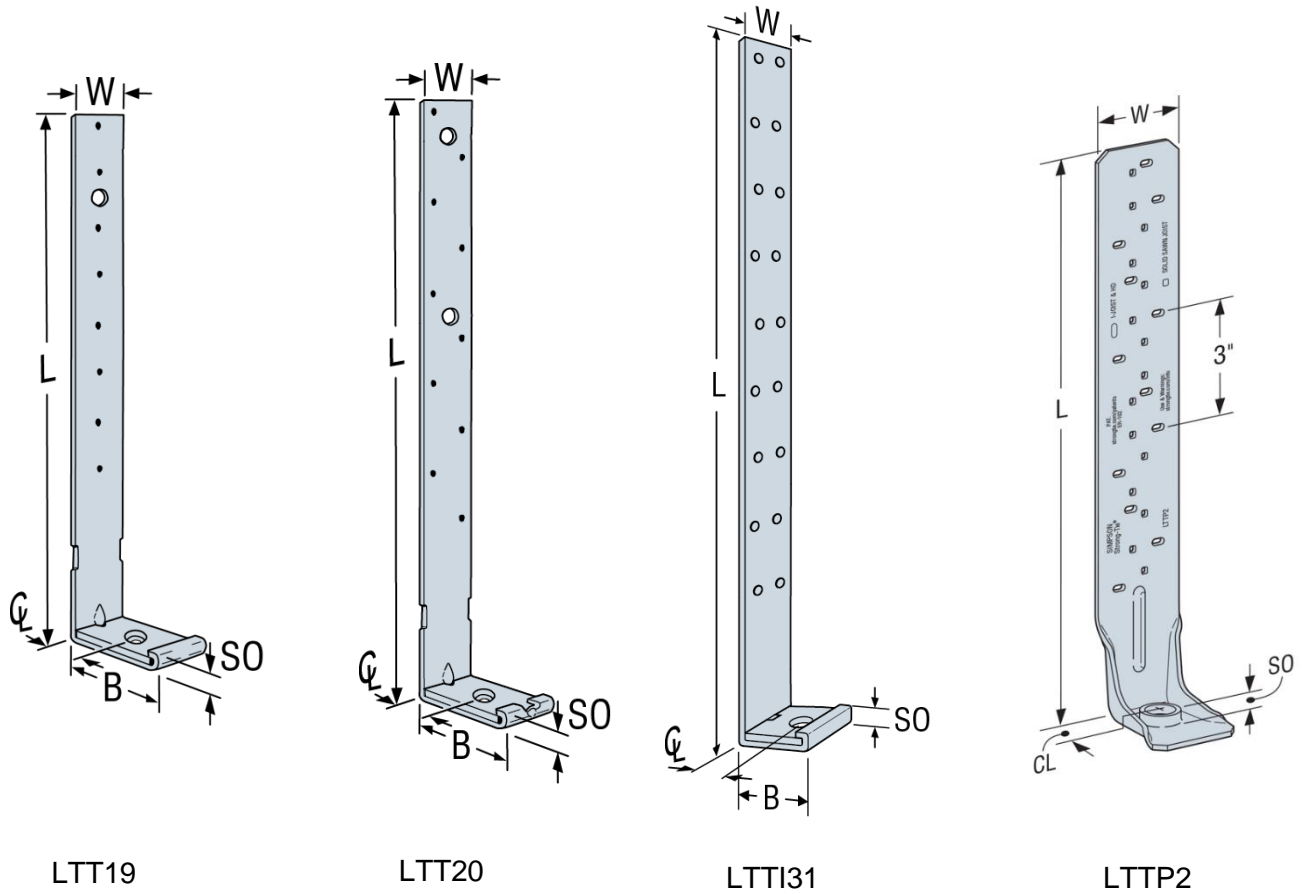

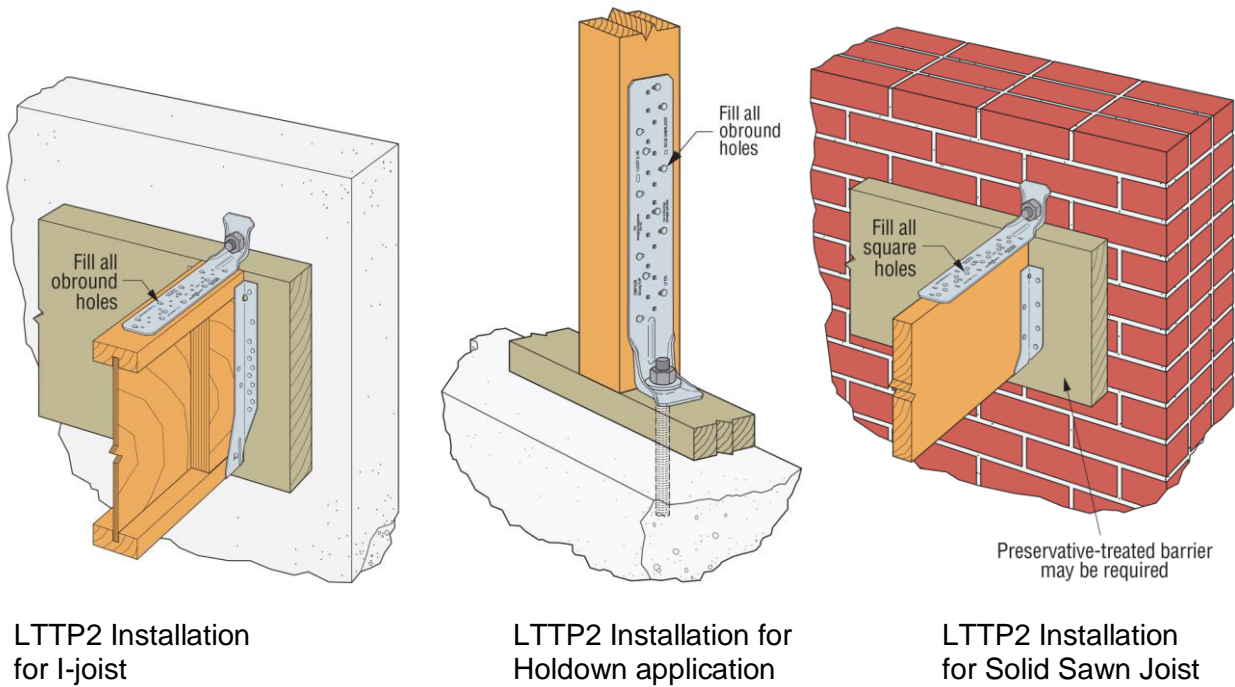

LTT2 Installation for I-joist

LTT2 Installation for Hold-down application

LTT2 Installation for Solid Sawn Joist

Figure 1 – LTT Nail Hold-Downs

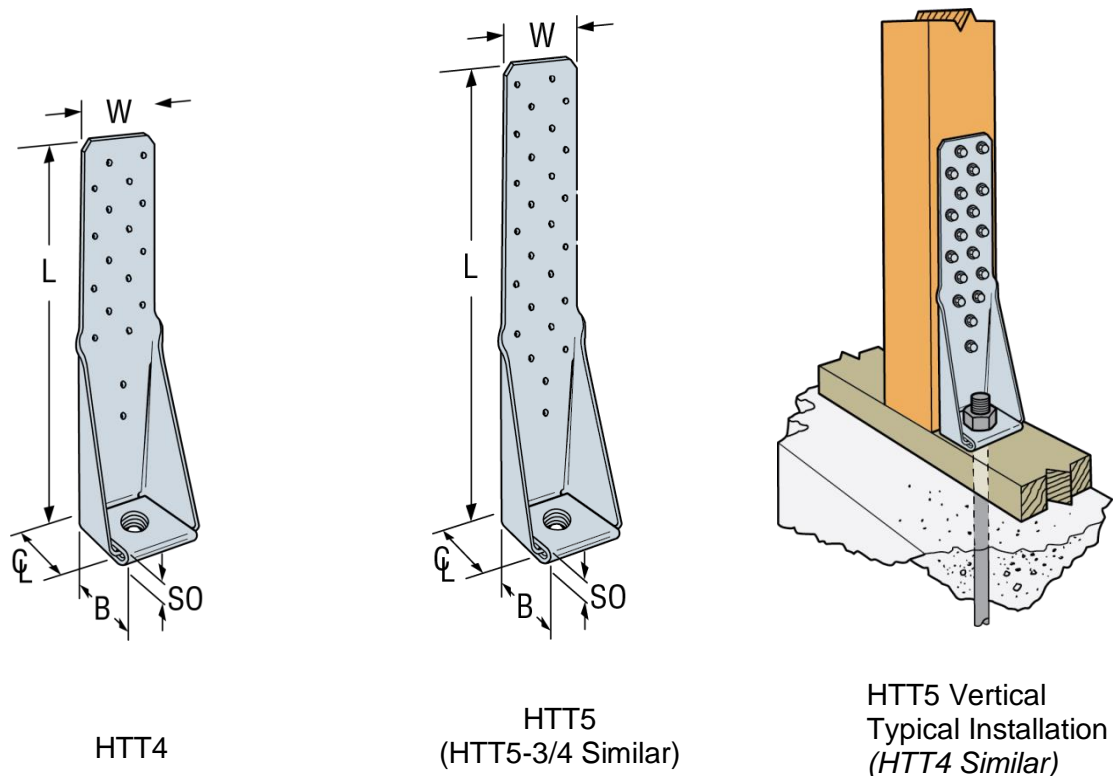

HTT4

HTT5 (HTT5-3/4 Similar)

HTT5 Vertical Typical Installation (HTT4 Similar)

Figure 2 – HTT Nail Hold-Downs

TABLE 2: ALLOWABLE LOADS FOR THE DTT1 HOLD-DOWN ^{1,2,3,12}

MODEL NO.	FASTENERS		MIN WOOD MEMBER THK. (in.)	ALLOWABLE TENSION LOADS, P_{all} (lbs.)				DISPLACEMENT, Δ , AT MAXIMUM LOAD ^{7,8,9} (in.)	
	ANCHOR DIAMETER & TYPE ⁴	FASTENER QUANTITY		DRY ⁵ , $C_M = 1.0$		WET ⁶ , $C_M = 0.7$		Δ_{all}	Δ_s
				$C_D = 1.0$	$C_D = 1.6$	$C_D = 1.0$	$C_D = 1.6$		
DTT1Z	3/8" ¹⁰ or SDWH ¹¹	6-SD9112	1 1/2	840	840	720	840	0.170	0.250
		6-10dx1 1/2	1 1/2	755	910 ¹¹	530	795	0.167	0.250
		8-10dx1 1/2	1 1/2	910 ¹¹	910 ¹¹	705	910 ¹¹	0.167	0.250

SI: 1 inch = 25.4 mm, 1 lb. = 4.45 N.

1. Tabulated allowable loads are for a hold-down assembly consisting of the hold-down device attached to a 1 1/2-inch thick wood structural member with the fasteners noted in Table 2.
2. The allowable loads for the hold-down assemblies are based on allowable stress design (ASD) and include the load duration factors, C_D , corresponding with a normal duration of load ($C_D = 1.0$), and wind/earthquake loading ($C_D = 1.6$) in accordance with the NDS. No further increase is allowed. Where other load durations govern, the values under $C_D = 1.0$ shall be adjusted accordingly.
3. When using the basic load combinations in accordance with 2021 IBC Section 1605.1 (ASCE 7-16 Section 2.4), or 2018 (2015) (2012) (2009) IBC Section 1605.3.1, the tabulated allowable loads for the hold-down assembly shall not be increased for wind or earthquake loading. When using the alternate basic load combinations in 2021 IBC Section 1605.2, or 2018 (2015) (2012) (2009) IBC Section 1605.3.2 that includes wind or earthquake loads, the tabulated allowable loads for the hold-down assembly shall not be increased by 33 1/3 percent, nor shall the alternative basic load combinations be reduced by a factor of 0.75.
4. Anchorage to concrete or masonry shall be determined in accordance with Section 4.1.2 of this report.
5. Dry values are applicable to installations into wood members with a moisture content that does not exceed 19 percent.
6. Wet values are applicable to installations into wood members with a moisture content greater than 19 percent at the time of installation or in service. Values include an NDS wet service factor for the fasteners ($C_M = 0.7$).
7. The tabulated allowable (ASD) tension loads shall be multiplied by 1.4 to obtain the strength-level resistance loads associated with the tabulated Δ_s deformations.
8. Tabulated displacement values, Δ_{all} and Δ_s , for hold-down assemblies include all sources of hold-down assembly elongation, such as fastener slip, hold-down device extension and rotation, and anchor rod elongation, at ASD-level and strength level forces respectively.
9. Elongation of the hold-down anchor rod shall be calculated when the actual unbraced length is greater than 2.5 inches, or ASTM steel specification of the anchor rod differs from that described in Section 3.2.4 of this report.
10. A 3/8 inch diameter round washer is required when using a 3/8 inch diameter machine bolt, anchor bolt, or lag screw.
11. The DTT1 installed with the Strong-Drive SDWH Timber-Hex HDG screw achieves the lesser of the table load or 855 lbs. The SDWH Timber-Hex HDG screw with a 3-inch minimum thread penetration into a supporting wood member with a minimum specific gravity of 0.50 has an allowable withdrawal load of 1,225 pounds, which includes a load duration factor of 1.6.
12. Tabulated values are for connectors installed flush with the end of the framing member or installed away from the end.

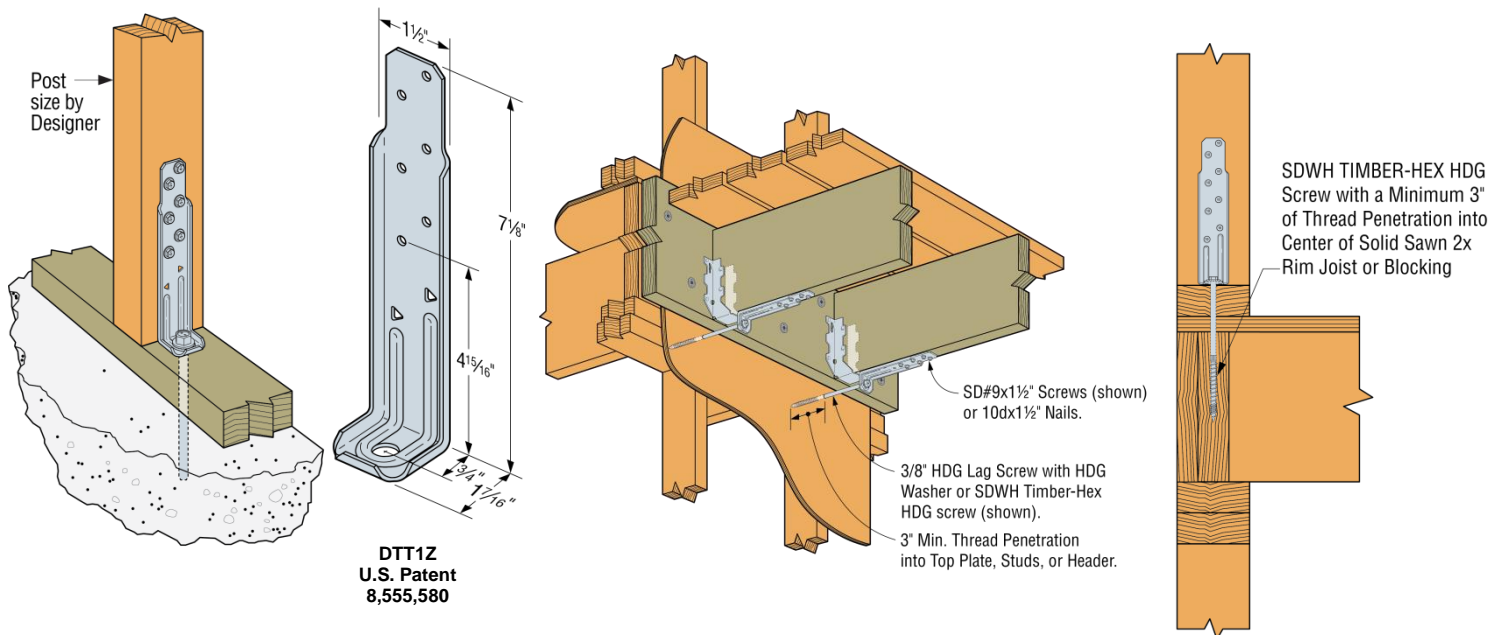

Figure 3 – DTT1 Nail Hold-Downs



CITY OF LOS ANGELES SUPPLEMENT

SIMPSON STRONG-TIE COMPANY INC.
5956 West Las Positas Boulevard
Pleasanton, California 94588
(800) 925-5099
www.strongtie.com

SIMPSON STRONG-TIE NAIL HOLD-DOWNS (TENSION TIES)

CSI Division:
06—WOOD, PLASTICS, AND COMPOSITES
CSI Section:
06 05 23—Wood, Plastic, and Composite
Fastenings

1.0 RECOGNITION

Simpson Strong-Tie structural nail hold-down connectors (tension ties) described in ER-130 are acceptable alternatives to what is specified in the following codes and regulations:

- 2020 City of Los Angeles Building Code (LABC)
- 2020 City of Los Angeles Residential Code (LARC)

2.0 LIMITATIONS

Use of the Simpson Strong-Tie structural nail hold-down connectors (tension ties) recognized in this supplement are subject to the following limitations in addition to the limitations shown in ER-130:

2.1 References in IAPMO UES ER-130 to section numbers of the 2018 IBC and 2018 IRC are the same section numbers in the LABC and LARC, as applicable.

2.2 Hold-down connectors designed to resist shear wall overturning moments shall be reduced to 75 percent of the allowable load values shown in Tables 1 and 2 of ER-130, in accordance with LABC Section 2305.5.

2.3 Engineered designs submitted in accordance with LARC Section R301.1.3 shall also comply with LARC Section R301.1.3.1.

2.4 Design, installation, and inspection shall be in accordance with Chapters 16 and 17 of the LABC, as applicable.

2.5 The use as flexible horizontal diaphragm to rigid wall anchor connectors is outside the scope of this supplement.

2.6 This supplement expires concurrently with ER-130.

For additional information about this evaluation report please visit www.uniform-es.org or email us at info@uniform-es.org



FLORIDA SUPPLEMENT

EVALUATION SUBJECT:
SIMPSON STRONG-TIE NAIL HOLD-DOWNS
(TENSION TIES)

REPORT HOLDER:
SIMPSON STRONG-TIE COMPANY, INC.
5956 West Las Positas Boulevard
Pleasanton, California 94588
(800) 925-5099
www.strongtie.com

CSI Division: 06-WOOD, PLASTICS, AND
COMPOSITES
CSI Section: 06 05 23-Wood, Plastic, and Composite
Fastenings

1.0 RECOGNITION

Simpson Strong-Tie structural nail hold-down connectors (tension ties) have been evaluated for structural performance properties, subject to the requirements in ER-130 and this supplemental report for compliance with the following codes and regulations:

- 2020 Florida Building Code, Building (FBC–Building)
- 2020 Florida Building Code, Residential (FBC–Residential)

2.0 LIMITATIONS

Simpson Strong-Tie structural nail hold-down connectors (tension ties) described in IAPMO UES ER-130 complies with the 2020 FBC–Building and the 2020 FBC–Residential, subject to the following limitations:

- 2.1** The design and installation of the Simpson Strong-Tie® structural nail hold-down connectors (tension ties) shall be in accordance with the 2018 International Building Code and the 2018 International Residential Code as noted in ER-130.
- 2.2** Load combinations shall be in accordance with Sections 1605.2 or 1605.3 of the FBC–Building, as applicable.
- 2.3** Design wind loads shall be in accordance with Section 1609.5 of the FBC–Building or Section R301.2.1.1 of the FBC–Residential, as applicable, and Section 1620 of the FBC–Building where used in High-velocity Hurricane Zones (HVHZ).
- 2.4** Use of Simpson Strong-Tie® structural nail hold-down connectors (tension ties) recognized in this report

complies with the High-velocity Hurricane Zone (HVHZ) provisions set forth in Section 2122.7 of the FBC–Building. Where used in accordance with Section 2122.7.2 of FBC–Building, the connectors shall be designed to provide a positive direct connection to resist the horizontal forces as required in Section 1620 (HVHZ) of the FBC–Building or 200 pounds per lineal foot (2919 N/m), whichever is greater, in accordance with FBC–Building Section 2122.7.3.

- 2.5** Use of Simpson Strong-Tie® structural nail hold-down connectors (tension ties) recognized in this supplement complies with the High-velocity Hurricane Zone (HVHZ) provisions set forth in Section 2324.2 of the FBC–Building. Where used in accordance with Section 2321.6 of FBC–Building, the structural angles, clips, and ties shall be designed to resist the uplift forces as required in Section 1620 (HVHZ) of the FBC–Building or 700 pounds (3114 N), whichever is greater, in accordance with FBC–Building Section 2321.7.
- 2.6** Simpson Strong-Tie structural nail hold-down connectors (tension ties) shall be manufactured, identified, and installed in accordance with ER-130 and the manufacturer’s published installation instructions. A copy of the installation instructions shall be available at the job site continuously during installation. If there is a conflict between this report and the manufacturer’s published installation instructions, the more restrictive prevails.
- 2.7** For products falling Section (5)(d) of Florida Rule 61G20-3.001, verification that the report holder’s quality assurance program is audited by a quality assurance entity approved by the Florida Building Commission (or the building official when the report holder does not possess an approval by the Commission), to provide oversight and determine that the products are being manufactured as described in this evaluation report to establish continual product performance is required.
- 2.8** This supplement expires concurrently with ER-130.

For additional information about this evaluation report please visit
www.uniform-es.org or email us at info@uniform-es.org