



GDS INNOVATION LAB, LLC
831 Meridian St.
Duarte, CA 91010
(626) 535-9370
www.lifeark.net

LIFEARK MODULARS

ADDITIONAL COMPANY

LIFEARK SPC
831 Meridian St.
Duarte, CA 91010

CSI Section:

06 12 00 Structural Panels

1.0 RECOGNITION

The LifeArk Modulars recognized in this report have been evaluated for use as pre-fabricated integrated modular building systems with load-bearing walls, shear walls, floors, and roofs. The structural, durability, weather protection, roof fire classification, fire-resistance, and interior finish performance properties of the LifeArk Modulars comply with the intent of the provisions of the following codes and regulations:

- 2021, 2018, and 2015 International Building Code® (IBC)
- 2021, 2018, and 2015 International Residential Code® (IRC)
- 2022 and 2019 California Building Code® (CBC) – attached Supplement
- 2022 and 2019 California Residential Code® (CRC) – attached Supplement

2.0 LIMITATIONS

Use of the LifeArk Modulars recognized in this report is subject to the following limitations:

2.1 The LifeArk Modulars shall be designed and installed in accordance with the applicable code, the manufacturer’s published installation instructions, and this report. Where there is a conflict, the more restrictive shall govern.

2.2 Plans and calculations shall be submitted to the building official for approval at the time of permit application. Calculations shall demonstrate, in addition to other requirements as stipulated by the building official, that the applied loads are less than the design loads described in the IBC, IRC, or ASCE/SEI 7, and this report. The plans and calculations shall be prepared by a registered design professional where required by the statutes of the jurisdiction in which the project is to be constructed.

2.3 Weather protection for the LifeArk Modulars wall system shall comply with Section 1402.2 of the IBC and shall be designed and detailed and submitted to the building official for approval.

2.4 Allowable Stress Design (V_{asd}) cyclic shear design loads and lateral displacement (ΔV_{asd}) values for shear walls are limited to the values noted in Tables 2 and 3 of this report.

2.5 Use of the LifeArk Modulars wall systems in fire-resistance-rated assemblies is described in Section 3.2.6 of this report.

2.6 The LifeArk Modulars recognized in this report are produced by LifeArk, SPC, in Madera, CA.

3.0 PRODUCT USE

3.1 General: The LifeArk Modulars are used as pre-fabricated integrated modular building systems with load-bearing walls and shear walls, floors, and roofs.

3.2 Design: The structural design of the LifeArk Modulars shall be performed by a registered design professional according to acceptable engineering practices and shall reference the seismic design coefficients, factors, and Seismic Force-Resisting System limitations conforming to System A.15 or A.17 in Table 12.2-1 of ASCE/SEI 7. Tables 1 through 5 of this report provide the allowable stress design (ASD) for in-plane racking and cyclic shear walls, axial compression, and transverse uniform loads for the LifeArk Modulars.

3.2.1 In-Plane Shear Walls:

3.2.1.1 SDC A through D: The maximum allowable in-plane (racking) shear load for the LifeArk Modulars wall shown in Table 1 of this report is limited to use only in Seismic Design Categories A, B, C, and D, subject to the design coefficients, factors, and system limitations in ASCE Table 12.2-1 for A.17.

3.2.1.2 SDC A through F: The LifeArk Modulars may be used to resist as a seismic lateral force-resisting system in all seismic design categories, A through F in ASCE/SEI 7. Panels are load-bearing or non-loadbearing elements detailed to resist shear loads. Seismic loadings shall be determined in accordance with Section 1613 of the IBC and ASCE/SEI 7, and the design coefficients, factors, and system limitations shall be taken from ASCE/SEI 7 Table 12.12-1, System A-15. Wind loadings shall be determined in accordance with Section 1609 of the IBC and ASCE/SEI 7. Allowable stress design (V_{asd}) cyclic shear design loads and lateral displacement (ΔV_{asd}) values for wind and seismic forces are shown in Tables 2 and 3 of this report.

The product described in this Uniform Evaluation Service (UES) Report has been evaluated as an alternative material, design or method of construction in order to satisfy and comply with the intent of the provision of the code, as noted in this report, and for at least equivalence to that prescribed in the code in quality, strength, effectiveness, fire resistance, durability and safety, as applicable, in accordance with IBC Section 104.11. This document shall only be reproduced in its entirety.





3.2.1.3 Design of shear wall connections, such as uplift hold-downs, shear to base anchorage, and shear transfer from horizontal elements are beyond the scope of this report. The collectors and their connections, bearing, and anchorage of the panel, and the lateral load path to the panel are designed in accordance with the special load combinations of Section 12.4.4 of ASCE/SEI 7, using E_m , where E_m is calculated using the test panel overstrength. The registered design professional shall provide appropriate design and detailing information to the building official.

3.2.1.4 The maximum shear wall height-to-width aspect ratio is 2:1.

3.2.2 Axial Compression Wall Loads: The maximum allowable axial compression wall loads are shown in Table 4 of this report.

3.2.3 Transverse Loads: Table 5 of this report provides uniformly distributed transverse allowable (ASD) loads for wall panels that are laterally supported at the top and bottom for out-of-plane loads. Design of the floors, roofs, and wall panels supported on four sides shall be performed by a registered design professional according to accepted engineering practice and submitted to the building official for approval.

3.2.4 Combined Loads: Walls, floors, and roofs shall be designed using load combinations in accordance with Section 1605.3 of the IBC. For cases where the loads interact, such as loadbearing walls, the sum of the ratios of imposed loads to allowable loads shall not exceed one for allowable stress design (ASD).

3.2.5 Thermal Transmission: The LifeArk Modulares for walls, floors, and roofs have a thermal resistance, R-value of $35 \text{ ft}^2\cdot\text{hr}\cdot^\circ\text{F}/\text{Btu}$, and a thermal conductivity, k , of $0.171 \text{ Btu}\cdot\text{in}/\text{ft}^2\cdot\text{hr}\cdot^\circ\text{F}$ when tested in accordance with ASTM C518.

3.2.6 Fire-resistance-rated Wall Assemblies:

LifeArk Modulares wall assemblies comply with the fire-resistance rating as described in Sections 3.2.6.1 and 3.2.6.2 of this report. LifeArk Modulares wall assemblies, other than those described in Sections 3.2.6.1 and 3.2.6.2 of this report, are beyond the scope of this report. Details of the LifeArk Modulares wall assemblies are shown in Figure 3 of this report.

3.2.6.1 The LifeArk Modulares wall assembly complies with a one-hour fire-resistance rating in an load-bearing wall assembly with a maximum allowable load of 1789 plf (26.1 kN/m) when tested in accordance with ASTM E119. The LifeArk Modular wall assembly shall be a maximum of 8 feet, 2 inches (2489 mm) wide, and 9 feet, 5 inches (2870 mm) in height. The wall assembly has either two layers of $\frac{5}{8}$ -inch thick (16 mm) Type X gypsum wallboard on each side or one layer of $\frac{5}{8}$ -inch thick (16 mm) Type C

gypsum wallboard on each side that shall be fastened to the LifeArk Modulares with No.8 x $2\frac{1}{2}$ -inch-long drywall screws spaced 12 inches (305 mm) on center horizontally, and 10.3 inches (262 mm) on center vertically, and 1.5 inches (38.1 mm) from the edge of the gypsum board. The drywall screws and joints shall be taped and treated with joint compound in accordance with GA-214.

Alternatively, the use of $\frac{5}{8}$ -inch (16 mm) Type X or Type C glass mat gypsum board such as Georgia-Pacific DensGlass® Sheathing or Georgia-Pacific DensElement® Barrier System in lieu of Type X or Type C gypsum board mentioned in Section 3.2.6.1 of this report in the LifeArk Modulares wall assembly complies with the requirements for an exterior wall assembly with a one-hour fire resistance rating.

All gypsum products shall comply with the standards in Section 2506.2 of the IBC.

3.2.6.2 The LifeArk Modulares wall assembly complies with a 30-minute fire-resistance rating in a load-bearing wall assembly with a maximum allowable load of 1783 plf (26 kN/m) when tested in accordance with ASTM E119. The LifeArk Modular wall assembly shall be a maximum of 8 feet, 2 inches (2489 mm) wide, and 9 feet, 5 inches (2870 mm) in height. The wall assembly has either two layers of $\frac{5}{8}$ -inch thick (16 mm) Type X gypsum wallboard on each side or one layer of $\frac{5}{8}$ -inch thick (16 mm) Type C gypsum wallboard on each side that shall be fastened to the LifeArk Modulares with No.8 x $2\frac{1}{2}$ -inch-long drywall screws spaced 12 inches (305 mm) on center horizontally, 10.3 inches (262 mm) on center vertically, and 1.5 inches (38.1 mm) from the edge of the gypsum board. The drywall screws and joints shall be treated with joint compound in accordance with GA-214.

Alternatively, the use of $\frac{5}{8}$ -inch (16 mm) Type X or Type C glass mat gypsum board such as Georgia-Pacific DensGlass® Sheathing or Georgia-Pacific DensElement® Barrier System in lieu of Type X or Type C gypsum board mentioned in Section 3.2.6.2 of this report in the LifeArk Modulares wall assembly complies with the requirements for an exterior wall assembly with a 30-minute fire-resistance rating.

All gypsum products shall comply with the standards in Section 2506.2 of the IBC.

3.3 Installation: The LifeArk Modulares shall be installed in accordance with the applicable code, the manufacturer's published installation instructions, the project-specific structural calculations and details, and this report. The manufacturer's published installation instructions shall be available on the job site for quality control purposes during installation. If there are any conflicts between the project-specific structural calculations and details, the manufacturer's published installation instructions, and this report, the more restrictive shall govern.



3.3.1 Exterior Walls: The LifeArk Modulares shall have weather protection complying with Section 1402.2 of the IBC, which shall be designed and detailed and submitted to the building official for approval. The wall covering shall be installed to resist the applicable forces to the satisfaction of the building official.

3.3.2 Interior Finish: Except as provided for in IBC Sections 2603.4.1 and 2603.9, the LifeArk walls and ceiling shall be covered from the interior of a building by ½ inch (12.7 mm) thick gypsum wallboard or other approved thermal barrier in accordance with Section 2603.4 of the IBC or Section R316.4 of the IRC. The gypsum wallboard shall be fastened to the LifeArk Modulares wall and ceiling with #6-by-1½ -inch-long (38.1 mm) drywall screws spaced at a maximum of 16 inches (406 mm) on center horizontally and 12 inches (305 mm) on center vertically. When tested in accordance with NFPA 286, with a protective finish of ½ inch (12.7 mm) thick gypsum wallboard shall be fastened to the LifeArk Modulares wall and ceiling with #6-by-1½ -inch-long (38.1 mm) drywall screws spaced at a maximum of 16 inches (406 mm) on center horizontally and 12 inches (305 mm) on center vertically. The LifeArk Modulares comply with Section 803.1.1 of the IBC, and Section R316.6 of the IRC.

3.3.3 Roof: The LifeArk Modulares roof system shall comply with IBC Chapter 15. The minimum roof slope shall be in accordance with IBC Chapter 15 or IRC Chapter 9. The roof panel joints shall be weather protected by gaskets and caps, and the roof assembly shall be weather-proof. The roof system shall provide for proper drainage.

3.3.3.1 Roof Fire Classification: When installed in accordance with Section 3.3.3 of this report, the LifeArk Modulares roof system has a Class A roof fire classification when tested in accordance with ASTM E108. Recognition of the roof system is limited to the roof fire classification requirements in accordance with Section 1505 of the IBC or Section R902 of the IRC.

3.3.4 Floor: The LifeArk Modulares interior floor finish and floor covering materials shall be installed and limited to only the materials defined in the exception to Section 804.1 of the IBC.

4.0 PRODUCT DESCRIPTION

4.1 General: The LifeArk Modulares consist of a 0.24-inch (6.0 mm) thick high- or medium-density polyethylene (HDPE or MDPE) composite shells with 5.91-inch (150 mm) polyurethane foam plastic core. Figures 1 and 2 of this report illustrate system details.

4.2 Materials

4.2.1 Composite Shell: The HDPE or MDPE composite shell material is a proprietary masterbatch of non-halogenated and flame-retardant.

4.2.1.1 General: The HDPE or MDPE may have the same specific gravity but its molecular structure may be different and shall conform to Sections 4.2.1.2 and 4.2.1.3 of this report, as applicable.

4.2.1.2 HDPE: The HDPE shall conform as a Group 2, Class 3, Grade 1 plastic in accordance with ASTM D4976.

4.2.1.3 MDPE: The MDPE shall conform as a Group 2, Class 2, Grade 3 plastic, and may include a 30 percent proportion of post-consumer recycled polyethylene while complying with ASTM D4976.

4.2.2 The HDPU Foam Plastic Core: The HDPU foam plastic insulation core used in the LifeArk Modulares is rigid polyurethane manufactured by Foam Supplies Inc. as noted in UL Listing BRYX.R10576 or other approved alternatives. The polyurethane foam plastic insulation has a 6 inch (152 mm) maximum thickness with a nominal density of 1.8 pcf (29 kg/m³) and exhibits a flame-spread index of not more than 25 and a smoke-developed index of not more than 450 when tested in accordance with ASTM E84.

4.2.3 Hardware Details: Connections, fasteners, and accessories are outside the scope of this report and are subject to approval by the building official for each project. All connections, fasteners, and accessories used to erect the LifeArk Modulares shall be designed by a registered design professional and shall be submitted to the building official for approval.

5.0 IDENTIFICATION

The LifeArk Modulares components shall be labeled with the LifeArk logo, part number, and the evaluation report number (ER-560). Either IAPMO UES Mark of Conformity below may also be used.

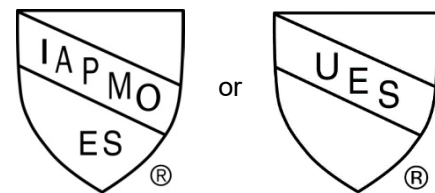

IAPMO UES ER-560

6.0 SUBSTANTIATING DATA

6.1 Data in accordance with the IAPMO Uniform Evaluation Service EC 035-2022, Evaluation Criteria for HDPE, MDPE, and Foam Composite Building Material.

6.2 Data in accordance with the IAPMO Uniform Evaluation Service EC 003-2022, Evaluation Criteria for the Testing and Analysis of Steel Sheet Sheathing for Wood and Cold-Formed Steel Light-Framed Structure Shear Walls.



Originally Issued: 02/27/2020

Revised: 04/23/2024

Valid Through: 02/28/2025

6.3 Data in accordance with the ICC-ES Acceptance Criteria for Prefabricated, Cold-formed Steel, Lateral-force-resisting Vertical Assemblies (AC322).

6.4 Reports of fire-resistance testing in accordance with ASTM E119.

6.5 Test reports are from laboratories in compliance with ISO/IEC 17025.

7.0 STATEMENT OF RECOGNITION

This evaluation report describes the results of research completed by IAPMO Uniform Evaluation Service on the LifeArk Modulares to assess conformance to the codes shown in Section 1.0 of this report and serves as documentation of the product certification. The LifeArk Modulares are manufactured at the location noted in Section 2.6 of this report under a quality control program with periodic inspection under the supervision of IAPMO UES.

For additional information about this evaluation report please visit www.uniform-es.org or email us at info@uniform-es.org

TABLE 1 – In-Plane (Racking) Shear Load

<u>Panel</u>	<u>Allowable Seismic Shear Load (plf)^{1,2,3,4}</u>
<u>5' x 8' Wall</u>	<u>113</u>

For SI: 1 inch =25.4 mm; 1 plf=1.49 kg/m

¹ Maximum allowable in-plane shear load capacity was determined from ASTM E72 testing.

² Allowable loads are based on a net horizontal deflection of 0.2 inch (5.1 mm).

³ Allowable drift limits shall comply with ASCE/SEI 7 Section 12.12, as applicable.

⁴ Allowable racking shear loads are limited to Seismic Design Categories A, B, and C.

TABLE 2 – Allowable Shear Resistance due to Wind and Seismic Forces and Displacement for Unloaded In-Plane Cyclic Shear Walls

<u>Load type¹</u>	<u>V_{asd} (lbs/ft)²</u>	<u>Δ V_{asd} (in) per panel height (7'-8'')³</u>	<u>Average G' (lbs/in)⁴</u>
<u>Seismic</u>	<u>95</u>	<u>0.46</u>	<u>419</u>
<u>Wind</u>	<u>139</u>	<u>0.51</u>	<u>419</u>

For SI: 1 inch =25.4 mm; 1 plf= 1.49 kg/m

¹ These values are for short-term loads due to wind or earthquake.

² V_{asd} = ASD Design Load.

³ Δ V_{asd} = Deflection at V_{asd} design Load.

⁴ G' = Secant shear modulus.

TABLE 3 – Allowable Shear Resistance due to Wind and Seismic Forces and Displacement for Loaded In-Plane Cyclic Shear Walls

<u>Load type¹</u>	<u>V_{asd} (lbs/ft)²</u>	<u>Δ V_{asd} (in) per panel height (7'-8'')³</u>	<u>Average G' (lbs/in)⁴</u>
<u>Seismic</u>	<u>96</u>	<u>0.46</u>	<u>305</u>
<u>Wind</u>	<u>141</u>	<u>0.51</u>	<u>305</u>

For SI: 1 inch =25.4 mm; 1 plf=1.49 kg/m

¹ These values are for short-term loads due to wind or earthquake.

² V_{asd} = ASD Design Load.

³ Δ V_{asd} = Deflection at V_{asd} design load.

⁴ G' = Secant shear modulus.

TABLE 4 – Allowable Axial Compression Loads on Wall Panels

Panel	Allowable Axial Load (plf) ^{1,2}
5' x 8' Wall	140

For SI: 1 inch =25.4 mm; 1 plf=1.49 kg/m

¹ Maximum allowable positive and negative transverse load capacity was determined from ASTM E72 testing.

² Allowable loads are based on a net axial deflection of 0.125 inch (3.2 mm).

TABLE 5 – Allowable (ASD) Uniform Transverse Loads on Wall Panels

Wall Panel	Allowable Positive Load (psf) ^{1,2}	Allowable Positive Deflection (in)	Allowable Negative Load (psf) ^{1,2}	Allowable Negative Deflection (in)
5' x 8'	13.9	0.76	13.9	0.8

For SI: 1 inch =25.4 mm; 1 psf=47.9 Pa

¹ Maximum allowable positive and negative transverse load capacity determined from tests in accordance with ASTM E2322 at an 8-foot span.

² Allowable loads are based on a factor of safety of 3.

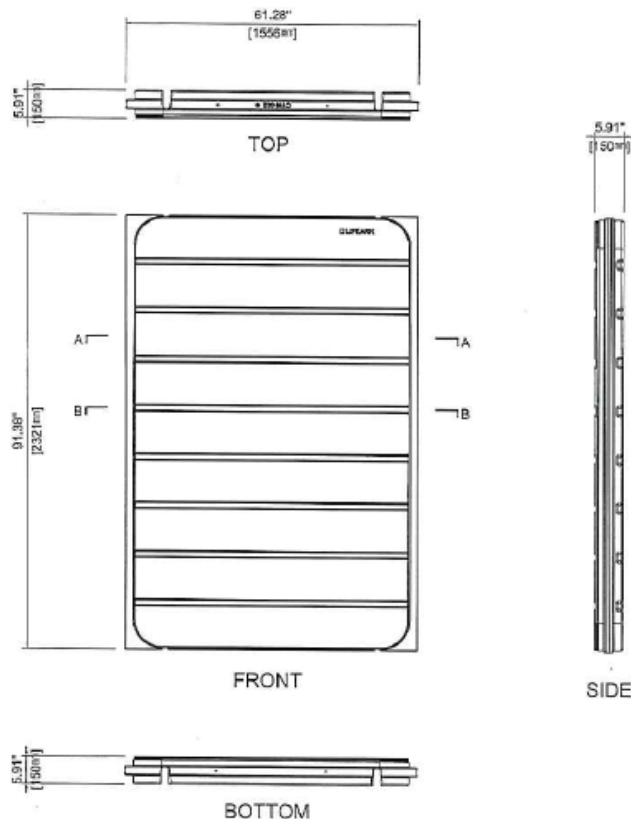

FIGURE 1 – LifeArk Modularity Detail

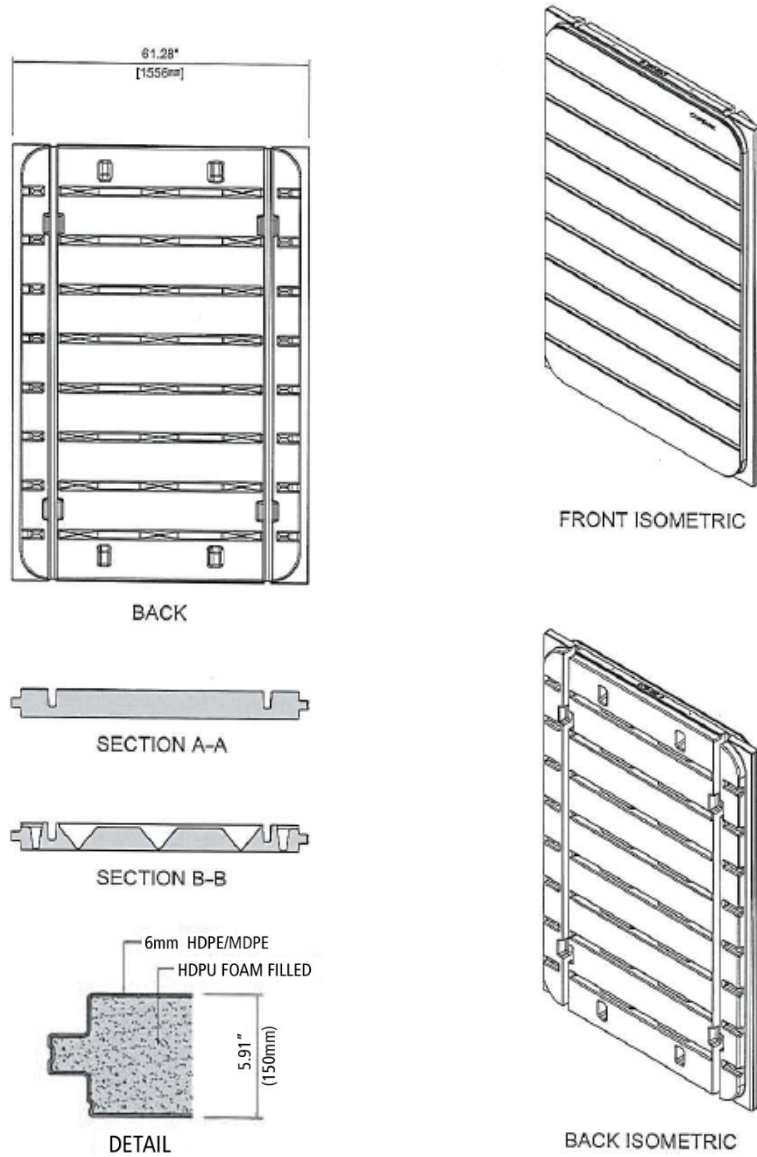

FIGURE 2 – LifeArk Modularity Detail

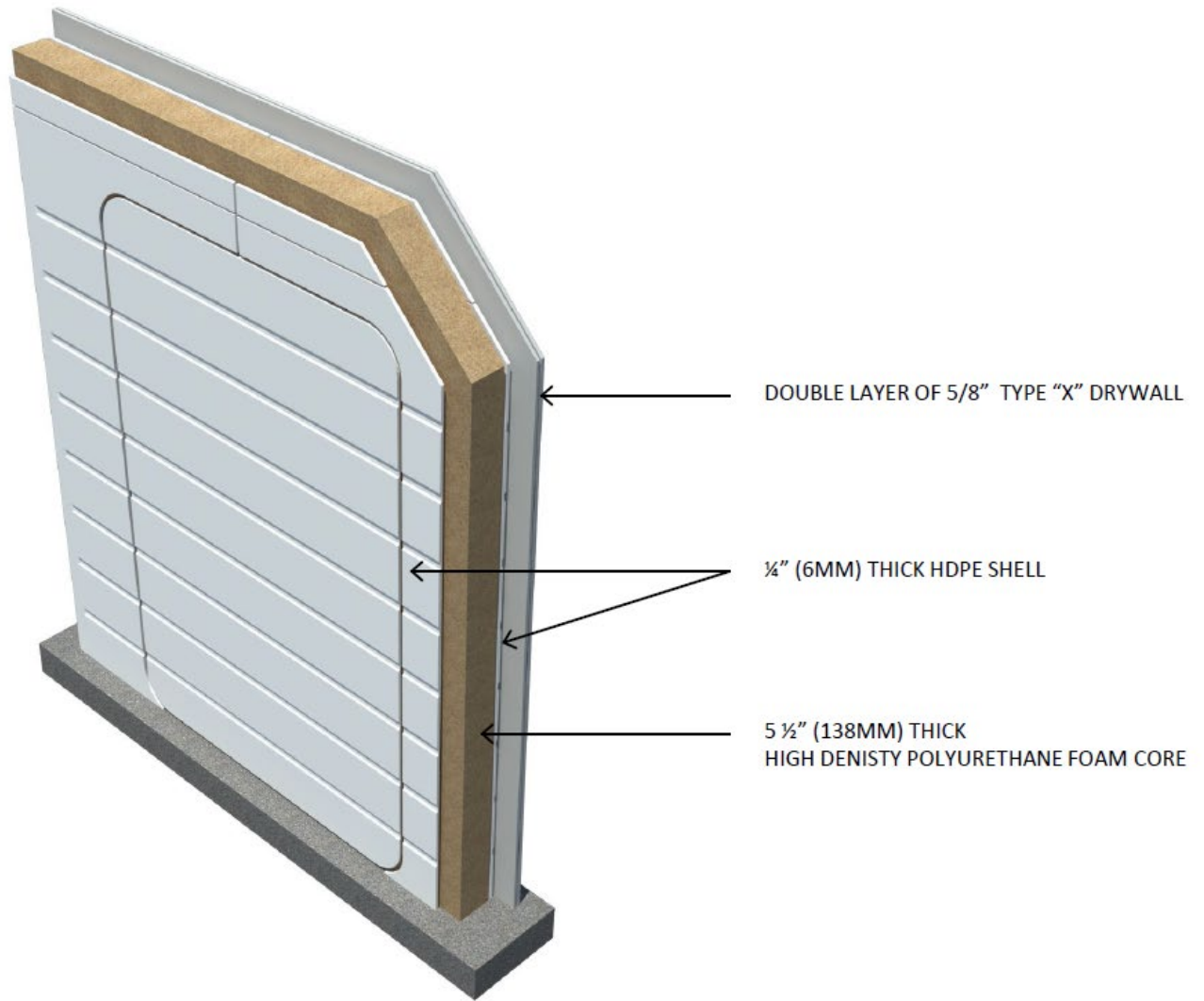

FIGURE 3 – LifeArk Fire-Resistance Wall Assemblies



CALIFORNIA SUPPLEMENT

GDS INNOVATION LAB, LLC
831 Meridian St.
Duarte, CA 91010
(626) 535-9370
www.lifeark.net

LIFEARK MODULARS

ADDITIONAL COMPANY

LIFEARK SPC
831 Meridian St.
Duarte, CA 91010

CSI Section:

06 12 00 Structural Panels

1.0 RECOGNITION

The LifeArk Modulars described in ER-560 and this supplement have been evaluated for use as pre-fabricated integrated modular building systems with load-bearing walls, shear walls, floors, and roofs. The structural, durability, weather protection, roof fire classification, and interior finish performance properties of the LifeArk Modulars are subject to the requirements in ER-560 and this supplemental report. LifeArk Modulars comply with the intent of the provisions of the following codes and regulations:

- 2022 and 2019 California Building Code® (CBC)
- 2022 and 2019 California Residential Code® (CRC)

2.0 LIMITATIONS

Use of the LifeArk Modulars recognized in this supplement is subject to the requirements in ER-560 and the following additional limitations:

2.1 The LifeArk Modulars shall comply with the provisions in ER-560 applicable to the 2021 IBC or IRC for use under the 2022 CBC or 2022 CRC, or the 2018 IBC or IRC for use under the 2019 CBC or 2019 CRC.

2.2 Plans and calculations shall be submitted to the building official for approval at the time of permit application. Calculations shall demonstrate, in addition to other requirements as stipulated by the building official, that the applied loads are less than the design loads described in the CBC, CRC, or ASCE/SEI 7 and ER-560. Building design calculations and details shall be prepared, stamped, and signed by a California registered design professional.

2.3 For applications regulated by DSA or HCAI – California Department of Health Care Access and Information (formerly OSHPD), structural calculations shall comply with CBC Section 1603A.3.

2.4 The LifeArk Modulars have not been evaluated in accordance with CBC Chapter 7A or CRC Section R337 for use in the exterior design and construction of new buildings located within a Wildland-Urban Interface Fire Area.

2.5 This supplement expires concurrently with ER-560.

For additional information about this evaluation report please visit www.uniform-es.org or email at info@uniform-es.org