



EVALUATION SUBJECT: SIMPSON STRONG-TIE® XL, XM, and X SELF- DRILLING TAPPING SCREWS FOR STEEL DECK DIAPHRAGMS

REPORT HOLDER:

Simpson Strong-Tie Company Inc.
5956 West Las Positas Boulevard
Pleasanton, California 94588
(800) 999-5099
www.strongtie.com

CSI Division: 05 – METALS

CSI Section: 05 05 23 – Metal Fastenings

CSI Section: 05 31 00 – Steel Decking

1.0 SCOPE OF EVALUATION

1.1 Compliance to the following codes & regulations:

- 2015 International Building Code® (IBC)
- 2015 International Residential Code® (IRC)
- 2012 International Building Code® (IBC)
- 2012 International Residential Code® (IRC)
- 2009 International Building Code® (IBC)
- 2009 International Residential Code® (IRC)

1.2 Evaluated in accordance with:

- IAPMO UES EC007- 2015, Adopted April 2015

1.3 Properties assessed:

- Structural

2.0 PRODUCT USE

The Simpson Strong-Tie® Strong-Drive® XL, XM, and X self-drilling tapping screws are used for the connection of steel deck complying with 2015 IBC and 2012 IBC Section [2210.1.1](#) or 2009 IBC Section [2209.2](#) in diaphragm construction. These fasteners attach the steel deck panels to supporting steel framing or attach the steel deck panels together at the panel side-laps.

3.0 PRODUCT DESCRIPTION

3.1 Product information: The Simpson Strong-Tie® self-drilling tapping screws for steel deck diaphragms include the Strong-Drive® XL Large-Head Metal Screw, the Strong-Drive® XM Medium-Head Metal Screw, and the Self-Drilling X Metal Screws.

The Simpson Strong-Tie® steel deck screws are case-hardened carbon steel conforming to [ASTM A510](#), minimum Grade 1022. [Tables 1](#) and [2](#) of this report provide depictions of the structural and side-lap fasteners

respectively, and the corresponding steel framing and deck thickness limits. [Table 3](#) of this report provides screw designations, sizes and descriptions of point styles. Screws are supplied in boxes of individual screws, or in collated plastic strips. [Figures 1](#) through 4 of this report provide depictions of screws described in Sections 3.2 and 3.3 of this report.

3.2 Structural Screws

3.2.1 Strong-Drive® XL Large-Head Metal Screws: XL screws are proprietary No. 12-24 self-drilling tapping screws, 1¼ inch (31.8 mm) long, with blue-bright zinc coating. The screws have a nominal shank diameter of 0.216 inch (5.49 mm), a 5/16 -inch (7.9 mm) hex head, and a 0.625-inch (15.88 mm) diameter integral washer. The XLQ screws have the same material properties as the XL screws, except for the finish, which is a proprietary Quik Guard® coating.

3.2.2 Strong-Drive® XM Medium-Head Metal Screws: XM screws are proprietary No. 12-24 self-drilling tapping screws, 1¼ inch (31.8 mm) long, with blue-bright zinc coating. The screws have a nominal shank diameter of 0.216 inch (5.49 mm), a 5/16 -inch (7.9 mm) hex head, and a 0.483-inch (12.27 mm) diameter integral washer. The XMQ screws have the same material properties as the XM screws, except for the finish, which is a proprietary Quik Guard® coating.

3.2.3 Self-Drilling X Metal Screws: X structural screws are No. 12-24 self-drilling tapping screws with a blue-bright zinc coating that comply with the performance requirements of [ASTM C1513](#). These screws have a nominal shank diameter of 0.216 inch (5.49 mm), a 5/16 inch (7.9 mm) hex head, and a 0.415-inch (10.5 mm) diameter integral washer. Screw lengths are 1¼ inches, and 1-½ inches (31.8, and 38.1 mm). The XQ screws have the same material properties as the X screws except for the finish, which is a proprietary Quik Guard® coating. The 1¼ inch long screws are available with either Quik Guard® or blue-bright zinc coating. The 1-½ inch long screws are only available with a proprietary Quik Guard® coating.

3.3 Side-lap Connections

3.3.1 Self-Drilling X Metal Screws: X side-lap screws are No. 10-16 self-drilling tapping screws with a blue-bright zinc coating that comply with the performance requirements of ASTM C1513. These screws have a nominal shank diameter of 0.190 inch (4.83 mm), and have 0.415-inch (10.54 mm) or 0.475-inch (12.07 mm) diameter hex washer heads. Screw lengths are ¾ inch (19.0 mm) or 1 inch (25.4 mm). The XQ screws have the same material properties as the X screws except for the finish, which is a proprietary Quik Guard® coating. XU screws are similar to X screws but have a smaller (under sized) drill point.



3.3.2 Verco PunchLok® II System: The Verco Sidlap Connection (VSC2) is an interlocking connection between the male and female lips of Verco steel roof deck panels as specified in Section 3.8 of IAPMO UES [ER-0217](#) made with the Verco PunchLok II tool. A VSC2 connection is made in either direction relative to the female lip. A VSC2 connection is made when the sidlap material has been sheared and offset so the sheared surface of the steel deck panel male leg is visible. The resulting VSC2 connection is illustrated in Figure 6 of IAPMO UES ER-0217. More information on the PunchLok II system and VSC2 is given in IAPMO UES ER-0217. VSC2 sidlap connections may be used in combination with the structural screws listed in Section 3.2 of this report.

3.3.3 ASC DeltaGrip™ System: The structural screws listed in Section 3.2 of this report may be used in combination with the DeltaGrip System sidlap connections. The DeltaGrip System sidlap connection is comprised of three triangular tabs produced by 3/8-inch-wide (9.5 mm) 60-degree triangular punches, that punch through and engage all the three layers of the sidlap standing seam interlock as specified in Section 3.5.1 of IAPMO UES ER-0161. Refer to Figure 12 of IAPMO UES ER-0161 for details. Delta Grip sidlap connection system is allowed from either side of the interlock. .

3.4 Steel Deck Panels: The steel deck panels shall be No. 16-gage [0.0598 inch (1.5 mm)], No. 18-gage [0.0474 inch (1.2 mm)], No. 20-gage [0.0358 inch (0.9 mm)], or No. 22-gage [0.0295 inch (0.8 mm)] nestable or interlocking B Deck, N Deck, A Deck, F Deck, or any other proprietary decks that are within the limitations of Section 1.2 (applicable deck types) of [SDI DDM03](#). The steel decks shall be cold-formed from [ASTM A653](#) or [ASTM A1008](#) SS Grade 33 (minimum) steel. [Figure 5](#) of this report shows some common deck profiles and dimensions.

3.5 Steel Support Framing: Structural steel supports for the steel deck panels (such as bar joists and structural steel shapes) shall be of materials complying with the requirements of [AISC 360](#) or [AISI S100](#). The supports shall be manufactured from code-complying steel having minimum strength requirements of [ASTM A36](#) and maximum strength requirements corresponding to Grade 50.

4.0 DESIGN AND INSTALLATION

4.1 Design: The nominal screw shear strength and tensile strength are listed in [Table 4](#) of this report. The structural fastener strength (Q_f) and the flexibility (S_f) used in steel deck to support framing connections are given in [Tables 5, 6, and 7](#) of this report. The side-lap fastener strength (Q_s) and flexibility (S_s) for panel side-lap connections are given in [Table 8](#) of this report. For connection shear, the lesser of the fastener shear strength and the connection shear capacity shall be used for design. For connections subject to tension, the least of the screw tensile strength, the connection pull-

over strength, and the connection pull-out strength found in [Tables 4, 9, 10, and 11](#) of this report shall be used for design. Design equations for calculating nominal steel deck diaphragm strength (S) and diaphragm stiffness (G') for deck panels shall comply with Sections 2 and 3 of Steel Deck Institute, Diaphragm Design Manual, 3rd edition, September 2004 (SDI DDM03). To calculate the design strengths, the safety and resistance factors for Allowable Strength Design (ASD) and Load and Resistance Factor Design (LRFD) provided in [Table 12](#) of this report shall be applied to the nominal values. The ASD and LRFD design values calculated using this report do not account for steel deck buckling and shall be compared with the corresponding buckling diaphragm shear strengths calculated in accordance with SDI DDM03. The lesser of the diaphragm shear and the buckling shear is used as the governing diaphragm design strength. The diaphragm strength calculated in accordance with this section is applicable to steel deck diaphragms where the steel deck panels are installed in a minimum three-span condition and the steel deck panels are attached to the diaphragm perimeter frame with fasteners installed at the same or closer spacing as the spacing of the interior side-lap connection.

The design equations and the load values in this report apply to steel deck panels complying with Section 3.4 of this report and some of the common fastener patterns shown in [Figure 5](#) of this report, with side-lap connection spacings ranging from 3 to 36 inches (76 to 914 mm).

When steel deck panels are used in a diaphragm as defined in Section [1602](#) of the IBC, the diaphragm length and width shall be limited by one of the following: engineering mechanics; applied loads; shear capacity of the diaphragm; diaphragm shear deflection limited by the requirements of [ASCE 7](#) in Sections 12.8.6 titled “Story Drift Determination” or Section 12.12 titled, “Drift and Deformation”. The shear deflection is based on the stiffness or flexibility factors for the diaphragm and equations of mechanics. Common shear deflection equations as shown in [Table 13](#) of this report may be used.

Screw thread length and point style shall be selected on the basis of thickness of the fastened material and the thickness of support material respectively in accordance with Simpson Strong-Tie’s published installation instructions.

4.2 Installation: The Simpson Strong-Tie steel deck self-drilling tapping screws shall be installed in accordance with the Simpson Strong-Tie installation instructions and this report. Where conflicts occur, the more restrictive shall govern. The Simpson Strong-Tie published installation instructions shall be available at the jobsite at all times during installation. The screws shall be installed perpendicular to the work surface using a screw gun or drill motor with a maximum speed of 2,500 rpm using a 5/16-inch hex driver. The screw shall penetrate through the supporting steel with a minimum of three threads protruding past the back side of the



supporting steel. Minimum Screw spacing's shall comply with Section E4.1 of AISI S100-07/S2-10 and minimum screw edge distances shall comply with Section E4.2 of AISI S100-07/S2-10.

At end laps, the steel deck panels shall be sufficiently overlapped to provide adequate end distances for the fastener. The minimum end distance for fasteners shall be 1 inch (25.4 mm), requiring an end lap not less than 2 inches (50.8 mm). End lap and corner lap conditions of multiple deck layers shall be snug and tight to one another and the supporting steel frame, prior to frame fastener attachment. At side-lap attachments, the overlapping edges of panels shall be in close contact to minimize eccentricity of fasteners in the lap. When side-lap fasteners connect adjacent panels between supports, equivalent or superior fasteners shall be installed connecting the panels at the outermost edge of the diaphragm perimeter. At side-laps for interlocking decks using VSC2 or DeltaGrip™ connections, follow the manufacturer's installation instruction.

The support fasteners shall be installed in a specified pattern as shown in [Figure 5](#) of this report. The side-lap connection spacing shall not exceed 36 inches (914 mm) on center.

5.0 LIMITATIONS

The Simpson Strong-Tie® XL, XM and X steel deck screws as described in this report comply with, or are suitable alternatives to what is specified in, those codes listed in Section 1.0 of this report, subject to the following conditions:

5.1 The fasteners are manufactured, identified and installed in accordance with this report, the manufacturer's instructions, and the approved plans. If there is a conflict, the more restrictive shall govern.

5.2 The design of steel deck panels for vertical loads is outside the scope of this report and shall comply with applicable code requirements.

5.3 Diaphragm shear strength and stiffness shall be calculated in accordance with [Tables 4](#) through 12 of this report and Sections 2, 3 and 5 of Steel Deck Institute, Diaphragm Design Manual Third Edition (DDM03).

5.4 No adjustment for duration of load is permitted.

5.5 Steel deck diaphragms may be zoned by varying steel deck panel gage and/or connections across a diaphragm to meet varying shear and flexibility or stiffness demands.

5.6 Use within fire-resistance-rated assemblies is beyond the scope of this report.

5.7 Acoustic performance for sound transmission coefficient and impact insulation class is beyond the scope of this report.

5.8 Calculations demonstrating compliance with this report shall be submitted to the code official for approval. The calculations shall be prepared by a registered design professional where required by the statutes of the jurisdiction in which the project is to be constructed.

5.9 Simpson Strong-Tie steel deck screws may be used for fastening steel deck roof systems temporarily exposed to the exterior during construction prior to application of built-up roof covering systems. The fasteners on steel deck permanently exposed to weather or moisture, such as roof coverings, are outside the scope of this report.

6.0 SUBSTANTIATING DATA

Data and test reports submitted are from laboratories in compliance with [ISO/IEC 17025](#) and in accordance with the IAPMO UES, Evaluation Criteria for Steel Composite, Non-Composite and Roof Deck Construction EC 007, Adopted April 2015.



7.0 IDENTIFICATION

The Simpson Strong-Tie steel deck self-drilling tapping screws are marked with a No-Equal symbol (\neq) on the top surface of the screw heads, as shown in [Figure 1](#) to 4 of this report. Packages of Simpson self-drilling tapping screws are labeled with the report holder's name (Simpson Strong-Tie Company Inc.) and address, the fastener type and size, and the IAPMO Uniform ES evaluation report number (ER-326). All model numbers may have a "B" substituted for "S", "T", or "R", where "B", "S", "T", and "R" stand for "bulk", "strip-collated", "tape-collated", or "raw", respectively, otherwise the fasteners are exactly the same. The product numbers may have a hyphenated suffix (e.g., -2.5k, -3k, and -5k) that only describes package quantity.

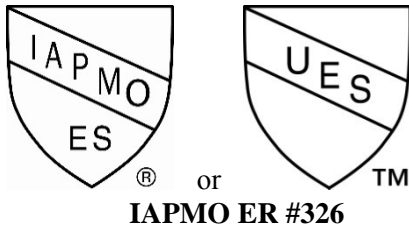

Brian Gerber

Brian Gerber, P.E., S.E.
Vice President, Technical Operations
Uniform Evaluation Service

Richard Beck



Richard Beck, PE, CBO, MCP
Vice President, Uniform Evaluation Service

Russ Chaney

GP Russ Chaney
CEO, The IAPMO Group

For additional information about this evaluation report please visit
www.uniform-es.org or email at info@uniform-es.org

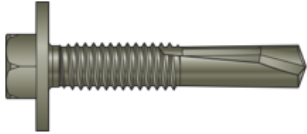
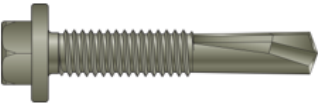
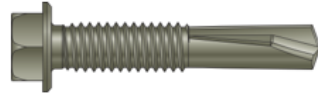
TABLE 1 – STRUCTURAL FASTENER SELECTOR GUIDE¹

Model Number(s)	Fastener Type	Suitable Material Thickness ² (in.)	Shear Tables Reference	Tension Tables Reference
XLQ114B1224-2K/ XLQ114T1224		0.125 - 0.500	4, 5, 6, 7	4, 9, 10, 11
XMQ114B1224-2K/ XMQ114S1224		0.125 - 0.500	4, 5, 6, 7	4, 9, 10, 11
XQ114S1224/ XQ114B1224-2.5K/ X114S1224		0.125 - 0.500	4, 5, 6, 7	4, 9, 10, 11
XQ112S1224/ XQ112B1224-2K		0.125 - 0.500	4, 5, 6, 7	4, 9, 10, 11

For SI: 1 inch = 25.4 mm

¹Section 7.0 of this report explains Model Number Identification

² Suitable thickness refers to the combined thickness of all connection members.

TABLE 2 – SIDE-LAP FASTENER SELECTOR GUIDE¹



Model Number(s)	Fastener Type	Suitable Deck Thickness ² (in.)	Shear Tables Reference	Tension Tables Reference
X34B1016-5K		0.110 – 0.175	4, 8	-
X1S1016/ X1B1016-4K /XQ1S1016/ XQ1B1016-4K		0.110 – 0.175	4, 8	-
XU34B1016-5K/ XU34S1016		0.030 – 0.110	4, 8	-



TABLE 3 – SIMPSON STRONG-TIE® STEEL DECK SCREW PROPERTIES

Model Number(s)	Designation (Size – TPI)	Nominal Diameter (in.)	Screw Length (in.)	Head Style	Point Number	Drill Capacity (in.)
XLQ114B1224-2K/ XLQ114T1224	#12-24	0.216	1 - ¼	Hex Washer	5	0.61
XMQ114B1224-2K/ XMQ114S1224	#12-24	0.216	1 - ¼	Hex Washer	5	0.61
XQ114S1224/ XQ114B1224-2.5K/ X114S1224	#12-24	0.216	1 - ¼	Hex Washer	5	0.61
XQ112S1224/ XQ112B1224-2K	#12-24	0.216	1 - ½	Hex Washer	5	0.61
X34B1016-5K	#10-16	0.190	¾	Hex Washer	3	0.26
X1S1016/ X1B1016-4K/ XQ1S1016/ XQ1B1016-4K	#10-16	0.190	1	Hex Washer	3	0.28
XU34B1016-5K/ XU34S1016	#10-16	0.190	¾	Hex Washer	1	0.20

For SI: 1 inch = 25.4 mm

TABLE 4 – SIMPSON STRONG-TIE® STEEL DECK SCREW SHEAR AND TENSION STRENGTH

Model Number(s)	Size	Nominal Dia. (in.)	Washer Dia. (in.)	NOMINAL ^{1,2}	
				Shear (lbs.)	Tension (lbs.)
				P _{ss}	P _{ts}
XLQ114B1224-2K/ XLQ114T1224	#12-24 x 1-¼"	0.216	0.625	3110	4985
XMQ114B1224-2K/ XMQ114S1224	#12-24 x 1-¼"	0.216	0.483		
XQ114S1224/ XQ114B1224-2.5K/ X114S1224	#12-24 x 1-¼"	0.216	0.415		
XQ112S1224/ XQ112B1224-2K	#12-24 x 1-½"	0.216	0.415		
X34B1016-5K	#10-16 x ¾"	0.190	0.415	1625	-
X1S1016/ XQ1S1016/ X1B1016-4K/ XQ1B1016-4K	#10-16 x 1"	0.190	0.415	1625	-
XU34B1016-5K/ XU34S1016	#10-16 x ¾"	0.190	0.475	1735	-

For SI: 1 inch = 25.4 mm, 1 lbf = 4.448 N

- ¹ P_{ss} and P_{ts} are nominal shear strength and nominal tension strength for the screw itself, respectively, and are the average (peak) value of all tests determined by independent laboratory testing.
- ² The ASD and LRFD strengths for tension shall be calculated using a safety factor Ω of 3.0 and the resistance factor Φ of 0.5 respectively. [Table 12](#) of this report tabulates the safety factors and resistance factors for calculating diaphragm shears.



TABLE 5 – SIMPSON STRONG-TIE® STEEL DECK STRUCTURAL SCREW FASTENER CONNECTION STRENGTH (Q_f) AND FLEXIBILITY (S_f) WITH STEEL MINIMUM YIELD STRENGTH $F_y = 33$ ksi^{1,2,3}

Model Number(s)	Factor	Support Thickness (in.)	Q_f (lbs.) and S_f (in/kip) ⁴			
			Deck Thickness, gage (in.)			
			No. 22 (0.0295)	No. 20 (0.0358)	No. 18 (0.0474)	No. 16 (0.0598)
XLQ114B1224-2K/ XLQ114T1224	Q_f	0.375	1985	2410	3110	-
		0.25	1870	2270	3005	3110
		0.1875	1790	2170	2875	3110
		0.125	1685	2045	2705	3110
	S_f	0.125 - 0.375	0.0076	0.0069	0.0060	0.0053
XMQ114B1224-2K/ XMQ114S1224	Q_f	0.375	1565	1895	2510	3110
		0.25	1565	1895	2510	3110
		0.1875	1215	1625	2475	3110
		0.125	1215	1625	2475	3110
	S_f	0.125 - 0.375	0.0076	0.0069	0.0060	0.0053
XQ114S1224/ XQ114B1224-2.5K/ X114S1224/ XQ112S1224/ XQ112B1224-2K	Q_f	0.375	1016	1233	1633	2060
		0.25				
		0.1875				
		0.125				
	S_f	0.125 - 0.375	0.0076	0.0069	0.0060	0.0053

For SI: 1 inch = 25.4 mm, 1 lbf = 4.448 N, 1 in/kip = 5.71 mm/kN, 1 ksi = 6.895 Mpa

- ¹. For shear connections, the lesser of the nominal shear fastener strength and nominal shear capacity found in [Tables 4](#) and [5](#), respectively, shall be used for design.
- ². Values are based on steel deck members with a minimum yield strength of $F_y = 33$ ksi and tensile strength of $F_u = 45$ ksi and structural steel support members with a minimum yield strength of $F_y = 36$ to 50 ksi and tensile strength of $F_u = 50$ to 65 ksi.
- ³. [Table 3](#) of this report tabulates the screw drill capacities.
- ⁴. [Table 12](#) of this report tabulates the safety factors and resistance factors for calculating diaphragm shears.
- ⁵. Interpolation of connection shear strength, Q_f and flexibility, S_f , is permitted for deck thicknesses not shown in table.



TABLE 6 – SIMPSON STRONG-TIE® STEEL DECK STRUCTURAL SCREW FASTENER CONNECTION SHEAR STRENGTH (Q_f) AND FLEXIBILITY (S_f) WITH STEEL MINIMUM YIELD STRENGTH $F_y = 40$ ksi^{1,2,3}

Model Number(s)	Factor	Support Thickness (in.)	Q_f (lbs.) and S_f (in/kip) ⁴			
			Deck Thickness, gage (in.)			
			No. 22 (0.0295)	No. 20 (0.0358)	No. 18 (0.0474)	No. 16 (0.0598)
XLQ114B1224-2K/ XLQ114T1224	Q_f	0.375	1985	2410	3110	-
		0.25	1870	2270	3005	3110
		0.1875	1790	2170	2875	3110
		0.125	1685	2045	2705	3110
	S_f	0.125 - 0.375	0.0076	0.0069	0.0060	0.0053
XMQ114B1224-2K/ XMQ114S1224	Q_f	0.375	1565	1895	2510	3110
		0.25	1565	1895	2510	3110
		0.1875	1215	1625	2475	3110
		0.125	1215	1625	2475	3110
	S_f	0.125 - 0.375	0.0076	0.0069	0.0060	0.0053
XQ114S1224/ XQ114B1224-2.5K/ X114S1224/ XQ112S1224/ XQ112B1224-2k	Q_f	0.375	1180	1430	1895	2390
		0.25				
		0.1875				
		0.125				
	S_f	0.125 - 0.375	0.0076	0.0069	0.006	0.0053

For SI: 1 inch = 25.4 mm, 1 lbf = 4.448 N, 1 in/kip = 5.71 mm/kN, 1 ksi = 6.895 Mpa

- ¹ For shear connections, the lesser of the nominal shear fastener strength and nominal shear capacity found in [Tables 4](#) and 6, respectively, shall be used for design.
- ² Values are based on steel deck members with a minimum yield strength of $F_y = 40$ ksi and structural steel support members with a minimum yield strength of $F_y = 36$ to 50 ksi and tensile strength of $F_u = 50$ to 65 ksi.
- ³ [Table 3](#) of this report tabulates the screw drill capacities.
- ⁴ [Table 12](#) of this report tabulates the safety factors and resistance factors for calculating diaphragm shears.
- ⁵ Interpolation of connection shear strength, Q_f , and flexibility, S_f , is permitted for deck thicknesses not shown in table.



TABLE 7-SIMPSON STRONG-TIE STEEL DECK STRUCTURAL SCREW FASTENER CONNECTION SHEAR STRENGTH (Q_f) AND FLEXIBILITY (S_f) WITH STEEL MINIMUM YIELD STRENGTH $F_y = 50$ ksi^{1,2,3}

Model Number(s)	Factor	Support Thickness (in.)	Q_f (lbs.) and S_f (in/kip) ⁴			
			Deck Thickness, gage (in.)			
			No. 22 (0.0295)	No. 20 (0.0358)	No. 18 (0.0474)	No. 16 (0.0598)
XLQ114B1224-2K/ XLQ114T1224	Q_f	0.375	2030	2465	3110	3110
		0.25	2465	2465	3110	3110
		0.1875	1945	2360	3110	3110
		0.125	1830	2220	2940	3110
	S_f	0.125 - 0.375	0.0076	0.0069	0.0060	0.0053
XMQ114B1224-2K/ XMQ114S1224	Q_f	0.375	1780	2200	2995	3110
		0.25	1780	2200	2995	3110
		0.1875	1655	2050	2790	3110
		0.125	1495	1850	2520	3110
	S_f	0.125 - 0.375	0.0076	0.0069	0.0060	0.0053
XQ114S1224/ XQ114B1224-2.5K/ X114S1224/ XQ112S1224/ XQ112B1224-2K	Q_f	0.375	1385	1680	2200	2805
		0.25				
		0.1875				
		0.125				
	S_f	0.125 - 0.375	0.0076	0.0069	0.006	0.0053

For SI: 1 inch = 25.4 mm, 1 lbf = 4.448 N, 1 in/kip = 5.71 mm/kN, 1 ksi = 6.895 MPa

- For shear connections, the lesser of the nominal shear fastener strength and nominal shear capacity found in [Tables 4](#) and [6](#), respectively of this report, shall be used for design.
- Values are based on steel deck members with a minimum yield strength of $F_y = 50$ ksi and structural steel support members with a minimum yield strength of $F_y = 36$ to 50 ksi and tensile strength of $F_u = 50$ to 65 ksi.
- [Table 3](#) of this report tabulates the screw drill capacities.
- [Table 12](#) of this report tabulates the safety factors and resistance factors for calculating diaphragm shears.
- Interpolation of connection shear strength, Q_f , and flexibility, S_f , is permitted for deck thicknesses not shown in table.
- For support fastener patterns with more than one fastener per deck flute, such as B deck with a 36/9 or 36/11 pattern, the fastening pattern shall be increased at the building perimeter, chords, collectors or other shear transfer elements to two fasteners per rib when design seismic (or wind) diaphragm shear capacities, q , exceed the values determined by the Equations 1 and 2. The design seismic (or wind) diaphragm shear capacity shall not exceed that determined from the specific patterns used, as applicable.

$$q_{limit} = \frac{12/d}{\Omega} \cdot Q_f \quad \text{[ASD] Equation 1}$$

$$q_{limit} = \phi \cdot \frac{12}{d} \cdot Q_f \quad \text{[LRFD] Equation 2}$$

Where:

- q_{limit} = Shear strength limitation for PLB-36, PLN-24 and PLN3 deck (plf)
- d = pitch (in)
- Ω = Safety Factor for Diaphragms (Table 12 of this report)
- ϕ = Resistance Factor for Diaphragms (Table 12 of this report)
- Q_f = Screw Fastener Connection Strength (lbs.)



TABLE 8 – SIMPSON STRONG-TIE® STEEL DECK SIDE-LAP SCREW FASTENER CONNECTION SHEAR STRENGTH (Q_s) AND FLEXIBILITY (S_s)^{1,2}

Model Numbers	Size	Nominal Dia. (in.)	Washer Dia. (in.)	Factor	Q _s (lbs.) and S _s (in/kip) ³			
					Deck Thickness, gage (in.)			
					No. 22 (0.0295)	No. 20 (0.0358)	No. 18 (0.0474)	No. 16 (0.0598)
X34B1016-5K/ X1S1016/ X1B1016-4K/ XQ1S1016/ XQ1B1016-4K	#10-16	0.190	0.415	Q _s	590	715	950	1195
				S _s	0.0175	0.0159	0.0138	0.0123
XU34B1016-5K/ XU34S1016	#10-16	0.190	0.475	Q _s	745	900	1195	-
				S _s	0.0175	0.0159	0.0138	-

For SI: 1 inch = 25.4 mm, 1 lbf = 4.448 N, 1 in/kip = 5.71 mm/kN, 1 ksi = 6.895 MPa

- For shear connections, the lesser of the nominal shear fastener strength and nominal shear capacity found in [Tables 4](#) and [7](#), respectively of this report, shall be used for design.
- Values are based on steel deck members with a minimum yield strength of F_y = 33 ksi and tensile strength of F_u = 45 ksi
- [Table 12](#) of this report tabulates the safety factors and resistance factors for calculating diaphragm shears.

TABLE 9 – SIMPSON STRONG-TIE® STEEL DECK STRUCTURAL SCREW FASTENER PULL-OVER STRENGTH WITH STEEL MINIMUM YIELD STRENGTH F_y = 33 ksi^{1,2,3,4}

Model Number(s)	Load Type	Pull-over (lbs.)			
		Deck Thickness, gage (in.)			
		No.22 (0.0295)	No.20 (0.0358)	No.18 (0.0474)	No. 16 (0.0598)
XLQ114B1224-2K/ XLQ114T1224	Nominal	1295	1705	2490	2775
	LRFD	840	1100	1625	1810
	ASD	525	690	1015	1135
XMQ114B1224-2K/ XMQ114S1224	Nominal	750	1020	1400	1930
	LRFD	485	655	915	1260
	ASD	305	415	570	790
XQ114S1224/ XQ114B1224-2.5K/ X114S1224/ XQ112S1224/ XQ112B1224-2K	Nominal	825	1005	1330	1675
	LRFD	415	500	665	840
	ASD	275	335	445	560

For SI: 1 inch = 25.4 mm, 1 lbf = 4.448 N, 1 in/kip, 1 ksi = 6.895 Mpa

- Values are based on steel deck members with a minimum yield strength of F_y = 33 ksi and tensile strength of F_u = 45 ksi.
- The values for model numbers XLQ114B1224-2K/ XLQ114T1224 and XMQ114B1224-2K/ XMQ114S1224 are based on tests in accordance with AISI Standard Test Method S905-08. The values for the rest of the model numbers are based on the calculations in accordance with [AISI S100-07](#), Section E4.
- The safety factor Ω and resistance factor Φ used to determine the ASD and LRFD strengths are based on AISI S100-07, Chapter F for tested connections and Section E4 for calculated connections.
- For tension connections, the lesser of the design tension fastener strength of screws and the design pull-over and pull-out found by [Tables 4](#), [9](#) or [10](#) and [11](#) of this report, shall be used for design.



TABLE 10 – SIMPSON STRONG-TIE® STEEL DECK STRUCTURAL SCREW FASTENER PULL-OVER STRENGTH WITH STEEL MINIMUM YIELD STRENGTH, $F_y = 40$ ksi^{1,2,3,4}

Model Number(s)	Load Type	Pull-over (lbs.)			
		Deck Thickness, ga (in.)			
		22 (0.0295)	20 (0.0358)	18 (0.0474)	16 (0.0598)
XLQ114B1224-2K/ XLQ114T1224	Nominal	1575	1990	2820	3075
	LRFD	1020	1285	1840	2005
	ASD	635	800	1150	1255
XMQ114B1224-2K/ XMQ114S1224	Nominal	910	1190	1590	2135
	LRFD	595	775	1035	1395
	ASD	370	485	650	870
XQ114S1224/ XQ114B1224-2.5K/ X114S1224/ XQ112S1224/ XQ112B1224-2K	Nominal	1065	1295	1710	2160
	LRFD	535	645	855	1080
	ASD	355	430	570	720

For SI: 1 inch = 25.4 mm, 1 lbf = 4.448 N, 1 ksi = 6.895 Mpa

- Values are based on steel deck members with a minimum yield strength of $F_y = 40$ ksi and tensile strength of $F_u = 50$ ksi.
- The values for model numbers XLQ114B1224-2K/ XLQ114T1224 and XMQ114B1224-2K/ XMQ114S1224 are based on tests in accordance with AISI Standard Test Method S905-08. The values for the rest of the model numbers are based on the calculations in accordance with AISI S100-07, Section E4.
- The safety factor Ω and resistance factor Φ used to determine the ASD and LRFD strengths are based on AISI S100-07, Chapter F for tested connections and Section E4 for calculated connections.
- For tension connections, the lesser of the design tension fastener strength of screws and the design pull-over and pull-out found by [Tables 4, 9](#) or 10 and [11](#) of this report, shall be used for design.

TABLE 11 – SIMPSON STRONG-TIE® STEEL DECK STRUCTURAL SCREW FASTENER PULL-OUT STRENGTH^{1,2,3}

Model Number(s)	Load Type	Pull-out (lbs.)			
		Support Thickness			
		1/8"	3/16"	1/4"	3/8"
XLQ114B1224-2K/ XLQ114T1224/ XMQ114B1224-2K/ XMQ114S1224/ XQ114S1224/ XQ114B1224-2.5K/ X114S1224/ XQ112S1224/ XQ112B1224-2K	Minimum Tensile Strength of Steel, $F_u = 65$ ksi				
	Nominal	1490	2240	2985	4475
	LRFD	745	1120	1490	2240
	ASD	495	745	995	1490
	Minimum Tensile Strength of Steel, $F_u = 50$ ksi				
	Nominal	1150	1720	2295	3445
	LRFD	575	860	1150	1720
	ASD	385	575	765	1150

For SI: 1 inch = 25.4 mm, 1 lbf = 4.448 N, 1 ksi = 6.895 Mpa

- Values are based on calculations in accordance with Section E4 of AISI S100-07.
- The tabulated ASD and LRFD loads are based upon a safety factor Ω of 3.0 and the resistance factor Φ of 0.5 as set forth in Section E4 of AISI S100-07.
- For tension connections, the lesser of the design tension fastener strength of screws and the design pull-over and pull-out found by [Tables 4, 9](#) or 10 and [11](#) of this report, shall be used for design.



TABLE 12– SAFETY FACTORS AND RESISTANCE FACTORS FOR DIAPHRAGM SHEAR^{1,2}

Load Type	Factor	Wind	Earthquake	Other
ASD	Ω	2.35	2.5	2.5
LRFD	Φ	0.70	0.65	0.65

^{1.} For ASD loads divide the nominal diaphragm shear strength calculated per Section 4.1 of this report by Ω .

^{2.} For LRFD loads multiply the nominal diaphragm shear strength calculated per Section 4.1 of this report by Φ .

TABLE 13– DIAPHRAGM SHEAR DEFLECTION EQUATIONS

Type of Loading	Loading Condition	Shear Deflection	
Simple Beam at Center	Uniform Load, w	$\Delta_w = \frac{wL^2}{8bG'}$	
Simple Beam at L ₁	Uniform Load, w	$\Delta_w = \frac{q_{ave}L_1}{G'}$	
Simple Beam at center	Point Load, P	$\Delta_w = \frac{PL}{4bG'}$	
Simple Beam at 1/3 points	Point Loads, P	$\Delta_w = \frac{PL}{3bG'}$	
Cantilever Beam at End	Uniform Load, w	$\Delta_w = \frac{PL^2}{2bG'}$	
Cantilever Beam at End	Point Load, P	$\Delta_w = \frac{PL}{bG'}$	
Relationship between flexibility factor and stiffness factor		$f = \frac{1000}{G'}$	
b =	Depth of diaphragm (ft)	P =	Concentrated load (lbs)
f =	Flexibility factor (micro in/lbs)	q _{ave} =	Average diaphragm shear (lbs/ft)
G' =	Stiffness factor (kips/in)	w =	Uniform load (lbs/ft)
L =	Diaphragm Length (ft)	Δ_w =	Web deflection (in)
L ₁ =	Distance to point where deflection is calculated (ft)		

FIGURES 1 to 4 SIMPSON STRONG-TIE STEEL DECK SELF-DRILLING TAPPING SCREWS



FIGURE 1: STRONG-DRIVE® XL LARGE-HEAD METAL SCREW (STRUCTURAL SCREW)



FIGURE 2: STRONG-DRIVE® XM MEDIUM-HEAD METAL SCREW (STRUCTURAL SCREW)



FIGURE 3: SELF-DRILLING X METAL SCREW (STRUCTURAL SCREW)



FIGURE 4: SELF-DRILLING X METAL SCREW (SIDE-LAP SCREWS)

FIGURE 5 – DECK PROFILES AND FASTENER PATTERNS

B, BI DECK

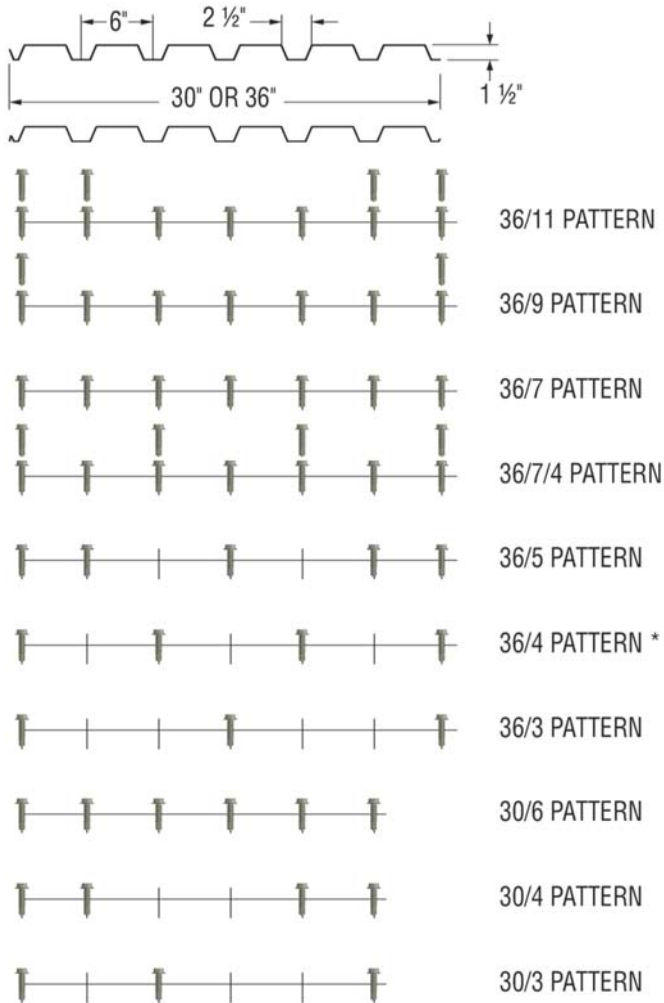

N, NI DECK

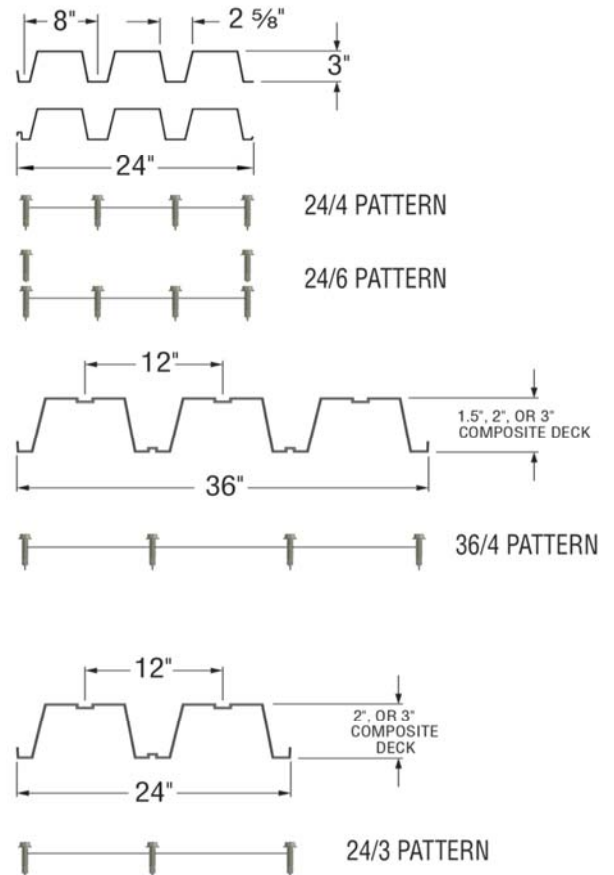

* THIS PATTERN IS ALSO USED FOR COMPOSITE DECKS.

NOTE: The fastener patterns shown are common patterns. The same fastener patterns are also used for F, FI, A, AI decks or other proprietary decks as described in Section 3.4 of this report.