



**MITEK INC.**  
16023 Swingley Ridge Rd.  
Chesterfield, MO 63017  
800-328-5934  
[www.mitek-us.com](http://www.mitek-us.com)  
[uspcustomerservice@mii.com](mailto:uspcustomerservice@mii.com)

## MITEK HOLD-DOWN AND TENSION-TIE CONNECTOR

**CSI Section:**  
06 05 23 Wood, Plastic, and Composite Fastenings

### 1.0 RECOGNITION

The MiTek Hold-down and Tension-tie Connectors recognized in this report have been evaluated for use as tie-downs, framing anchors, connectors, and mechanical connections for wood framing anchorage. The structural performance properties of the tie-downs (hold-downs) and connectors comply with the intent of the provisions of the following codes and regulations:

- 2021, 2018, 2015, and 2012 International Building Code® (IBC)
- 2021, 2018, 2015, and 2012 International Residential Code® (IRC)
- 2023 and 2020 Florida Building Code®, Building (FBC, Building) – attached supplement.
- 2023 and 2020 Florida Building Code®, Residential (FBC, Residential) – attached supplement.
- 2023 City of Los Angeles Building Code (LABC) – attached supplement.
- 2023 City of Los Angeles Residential Code (LARC) – attached supplement.

### 2.0 LIMITATIONS

Use of the MiTek Hold-down and Tension-tie Connectors recognized in this report is subject to the following limitations:

**2.1** The hold-downs and connectors shall be manufactured, identified, and installed in accordance with this report and the manufacturer's published installation instructions. Where conflicts occur, the more restrictive shall govern. A copy of the manufacturer's published instructions shall be available at the job site during installation.

**2.2** Project-specific calculations and details shall be prepared by a registered design professional and submitted to the building official where required by the statutes of the jurisdiction in which the project is to be constructed.

**2.3** A statement of special inspection shall be prepared by a registered design professional in responsible charge and submitted to the building official for approval where required by Section 1704.2.3 of the IBC.

**2.4** Connected wood members and fasteners shall comply with Section 4.2 of this report.

**2.5** Adjustment factors noted in Section 3.2.1 of this report and the applicable codes shall be considered, where applicable. Duration of load factors for earthquake or wind loading have already been applied in the allowable capacities for the products recognized in this report.

**2.6** Use of steel hold-downs and fasteners in contact with preservative-treated or fire-retardant-treated wood shall be in accordance with Section 4.2.7 of this report.

**2.7** Anchorage to concrete or masonry structural members shall be designed and detailed in accordance with Section 3.2.2 of this report.

**2.8** The hold-downs and connectors are manufactured by MiTek in Montgomery, MN; Largo, FL; and Tolleson, AZ.

### 3.0 PRODUCT USE

**3.1 General:** The MiTek Hold-down and Tension-tie Connectors described in this report are used as wood framing anchors in accordance with 2021 IBC Sections 2304.10.4, 2305.1, 2308.6.5.1, 2308.6.5.2; 2018 and 2015 IBC Sections 2304.10.3, 2305.1, 2308.6.5.1, and 2308.6.5.2; 2012 IBC Sections 2304.9.3, 2305.1, 2308.9.3.1, and 2308.9.3.2; and Sections 4.3.6.1.2 (Tension and Compression) and 4.3.6.4.2 (Uplift Anchorage at Shear Wall Ends) of the 2021, 2015, or 2008 ANSI/AWC Special Design Provisions for Wind and Seismic (SDPWS); as applicable. The hold-downs and connectors also are used to anchor wood structural elements to wood, concrete, or masonry to provide anchorage as required by Section 1604.8 of the IBC. The hold-downs and connectors may also be used in structures regulated under the IRC when an engineered design is submitted in accordance with IRC Section R301.1.3.

### 3.2 Design:

**3.2.1 Hold-down Assembly:** The allowable loads given in Tables 1 through 6 of this report are for hold-down assemblies consisting of the following components: (1) hold-down device(s); (2) an anchor bolt/rod attached to the seat of the device; (3) wood members having minimum specified dimensions and properties; (4) fasteners of a specified quantity, type, and size used to attach the devices to the wood members; and (5) specified bearing plates or washers.

*The product described in this Uniform Evaluation Service (UES) Report has been evaluated as an alternative material, design or method of construction in order to satisfy and comply with the intent of the provision of the code, as noted in this report, and for at least equivalence to that prescribed in the code in quality, strength, effectiveness, fire resistance, durability and safety, as applicable, in accordance with IBC Section 104.11. This document shall only be reproduced in its entirety.*

Copyright © 2024 by International Association of Plumbing and Mechanical Officials. All rights reserved. Printed in the United States. Ph: 1-877-4IESRPT • Fax: 909.472.4171  
web: [www.uniform-es.org](http://www.uniform-es.org) • 4755 East Philadelphia Street, Ontario, California 91761-2816 – USA





The allowable capacities given in the tables for these assemblies are based on Allowable Stress Design (ASD) and include the load duration factor,  $C_D$ , corresponding to the applicable loads, and the group action factor,  $C_g$ , where applicable, in accordance with the ANSI/AWC National Design Specification (NDS) for Wood Construction. Allowable strength values are applicable for designs complying with Sections 12.10 and 12.11.2 of ASCE/SEI 7.

Tabulated allowable loads are for hold-downs connected to wood used under continuously dry interior conditions, and where sustained temperatures are 100°F (37.8°C) or less. When hold-downs are fastened to wood that will experience sustained exposure to temperatures exceeding 100°F (37.8°C), the allowable loads shown in Tables 1 through 6 of this report shall be adjusted by the temperature factor,  $C_t$ , specified in the NDS.

When hold-downs are fastened to wood having a moisture content greater than 19 percent (16 percent for engineered lumber), or where wet service is expected, the allowable loads shown in Tables 1 through 6 of this report shall be adjusted by the wet service factor,  $CM$ , as specified in the NDS for lateral loads on dowel-type fasteners.

Hold-downs in contact with preservative-treated and fire-retardant-treated wood are subject to the approval of the building official, since the effects of corrosion of metal in contact with preservative and fire-retardant-treated wood on the structural performance of the devices is outside the scope of this report.

Wood members to which the hold-downs are attached shall be analyzed for allowable capacity at the critical net section for total combined stresses in accordance with the NDS, where applicable. Total combined stresses at the critical net section consist of flexural stress due to hold-down eccentricities relative to the centroid of the connected wood member ( $M_{xx}$  and  $M_{yy}$ ) combined with axial tension ( $T$ ) stress. When using the basic load combinations in accordance with 2021 IBC Section 1605.1 and ASCE/SEI 7 Section 2.4, or 2018, 2015, and 2012 IBC Section 1605.3.1, the tabulated allowable loads for the hold-down shall not be increased for wind or earthquake loading. When using the alternate basic load combinations in 2021 IBC Section 1605.2 or 2018, 2015, and 2012 IBC Section 1605.3.2 that include wind or earthquake loads, the tabulated allowable loads for the hold-down shall not be increased by 33⅓ percent, nor shall the alternative basic load combinations be reduced by a factor of 0.75.

Where design load combinations include earthquake loads or effects, story drifts of the structure shall be determined in accordance with Section 12.8.6 of ASCE/SEI 7, using strength-level seismic forces without reduction for ASD. The deflection of a shear wall restrained from overturning by hold-downs installed in accordance with this report is calculated using Equation 23-2 shown in Section 2305.3 of the IBC, or Equation 4.3-1 shown in Section 4.3.2 of the 2015

and 2008 SDPWS. The total deflection values,  $\Delta_{all}$  and  $\Delta_s$ , at ASD-level and strength-level forces, respectively, for hold-down assemblies given in Tables 1 through 6 of this report include all sources of hold-down assembly elongation, such as fastener slip, hold-down device extension and rotation, and anchor rod elongation where the height of the anchor rod extends 5 inches (127 mm) maximum above the foundation. The contribution of the hold-down anchor rod elongation in the total elongation (deflection) of the hold-down assembly shall be considered when the actual diameter, length, or ASTM steel specification of the anchor rod differs from that described in this report. When hold-downs occur in series, the cumulative deflection of all hold-downs shall be considered in the design. The effects of wood shrinkage on deflections, loosening of connections, and wood splitting at connections shall be considered in accordance with IBC Section 2303.7.

In calculating shear wall deflection at strength-level for earthquake, the symbol  $\Delta_s$ , as used in this report, shall replace the symbol  $d_a$  in Section 2305.3 of the IBC, and shall replace the symbol  $\Delta_a$  in Section 4.3.2 of the SDPWS.

**3.2.2 Anchorage to Concrete or Masonry:** Adequate embedment length and anchorage details, including edge and end distances, shall be determined and provided in accordance with Chapter 19 or 21 of the IBC, for the design of anchorage to concrete and masonry structural members. Where design load combinations include earthquake loads or effects, the design strength of the anchorage to concrete shall be determined in accordance with Section 1901.3 of the 2021, 2018, or 2015 IBC, or Section 1909 of the 2012 IBC, as applicable, except for detached one- and two-family dwellings assigned to Seismic Design Category A, B, or C, or located where the mapped short-period spectral response acceleration,  $S_s$ , is less than 0.4g as stated in Section 1613.1 of the IBC.

**3.3 Installation:** Installation of the hold-downs and connectors shall be in accordance with this evaluation report and the manufacturer's published installation instructions. Where conflicts occur, the more restrictive shall govern. The location of the hold-downs shall be in accordance with the approved plans, and fastener edge and end distances shall comply with this report.

When hold-down devices are attached to multi-ply framing members, the connection between laminations shall be designed in accordance with Section 15.3 of the 2018, 2015, or 2012 NDS, as applicable.

### 3.4 Special Inspection

**3.4.1 IBC:** Periodic special inspection is required for the installation of connectors described in this report that are designated as components of the seismic-force-resisting system for structures in Seismic Design Categories C, D, E, or F in accordance with Sections 1704.2 and 1705.12 of the 2021, 2018, or 2015 IBC, or Sections 1704.2 and 1705.11 of the 2012 IBC. Special inspections for anchor bolts in concrete



or masonry shall be conducted in accordance with Sections 1705.3 or 1705.4 of the 2021, 2018, 2015, or 2012 IBC, as applicable.

Periodic special inspection shall be conducted when the product series are components within the main wind-force-resisting system of structures constructed in areas listed in Section 1705.11 of the 2021, 2018, and 2015 IBC or Section 1705.10 of the 2012 IBC. For those structures that qualify under the Exceptions to Section 1704.2 of the IBC, special inspections may be omitted, subject to the provisions of the specific exception.

**3.4.2 IRC:** Special inspections are not generally required for connectors used in structures regulated under the IRC. However, when an engineered design is submitted or required pursuant to IRC Section R301.1.3, periodic special inspection requirements and exemptions are as stated in Section 3.4.1 of this report, as applicable.

## 4.0 PRODUCT DESCRIPTION

### 4.1 Product Information

**4.1.1 DTB-TZ Deck Tie Bracket:** The DTB-TZ connector consists of a main steel component with pre-punched holes for the installation of MiTek WS15-GC wood screws used to fasten the connector to the wood member, and a base component that provides a seat for an anchor rod, bolt, and nut as shown in Figure 1 of this report. [Table 1](#) and [Figure 1](#) of this report summarize dimensions, fastener schedule, allowable loads, and typical installation details.

**4.1.2 LTS and LTTI Tension Ties:** The LTS and LTTI connectors consist of a steel strap with pre-punched holes for the installation of nails or bolts used to fasten the connector to the wood member, and a base component that provides a seat for an anchor rod, bolt, and nut as shown in Figure 3 of this report. [Table 3](#) and [Figure 3](#) of this report provide stock numbers, product dimensions, fastener schedule, allowable loads, and typical installation details.

**4.1.3 PHD and PHDA Hold-downs:** The PHD and PHDA hold-downs consist of a main steel component with pre-punched holes for installation of MiTek WS3 wood screws used to connect the hold-down to the wood member, and a base plate component that provides a seat for an anchor rod, bolt, and nut as shown in Figure 4 of this report. The MiTek WS3 wood screws are provided with the PHD and PHDA hold-downs. [Table 4](#) and [Figure 4](#) of this report summarize stock numbers, product dimensions, fastener schedule, allowable loads, and typical installation details.

**4.1.4 UPHD Hold-downs:** The UPHD hold-downs consist of a main steel component with pre-punched holes for the installation of MiTek WS3 wood screws used to connect the hold-down to the wood member, and a base plate component that provides a seat for an anchor rod, bolt, and nut as shown in Figure 5 of this report. The MiTek WS3 wood screws are

provided with the UPHD hold-downs. [Table 5](#) and [Figure 5](#) of this report summarize stock numbers, product dimensions, fastener schedule, allowable loads, and typical installation details.

**4.1.5 TD and TDX Hold-downs:** The TD and TDX hold-downs consist of a main steel component with pre-punched holes for installation of bolts used to connect the hold-down to the wood member, and a base component that provides a seat for an anchor rod, bolt, and nut as shown in Figure 6 of this report. [Table 6](#) and [Figure 6](#) of this report summarize stock numbers, product dimensions, fastener schedule, allowable loads, and typical installation details.

### 4.2 Materials

**4.2.1 Steel:** The specific types of steel and corrosion protection for each product are described in [Table 7](#) of this report. Table 7 also gives the steel gage of each component. Minimum steel base-metal thicknesses for the different gages are shown in the following table:

GAGE NO.	DESIGN BASE-METAL THICKNESS (inch)	MINIMUM BASE-METAL THICKNESS (inch)
18	0.046	0.044
16	0.058	0.055
14	0.074	0.070
12	0.104	0.099
10	0.136	0.129
7	0.180	0.171
3	0.250	0.238

For **St**: 1 inch = 25.4 mm.

**4.2.2 Wood:** Wood members with which the hold-downs are used shall be sawn lumber with a minimum specific gravity of 0.50, or approved structural engineered lumber (structural composite lumber, alternative strand lumber, or prefabricated wood I-joists) with a minimum equivalent specific gravity of 0.50, unless otherwise noted in the applicable table within this report. The minimum dimensions of wood members are provided in the tables. Wood members shall have a moisture content not exceeding 19 percent (16 percent for structural engineered lumber), except as noted in Section 3.2 of this report. For connectors installed with nails or MiTek WS wood screws, the thickness of each wood member shall be sufficient to prevent the fasteners from protruding through the opposite side of the member. For installations in structural engineered lumber, minimum nail or screw spacing and end distance, as specified in the applicable evaluation report from an approved agency, shall be observed.

**4.2.3 Fasteners and Threaded Rod:** Required fastener types and sizes for use with the connectors described in this report are specified in Tables 1 through 6 of this report. Fasteners and threaded rods shall comply with Sections 4.2.4 through 4.2.6 of this report, as applicable. Under the IRC, fasteners used in deck construction shall comply with IRC Section R507.2.3.

**4.2.4 Bolts and Threaded Rod:** At a minimum, bolts and threaded rods shall comply with ASME 1318.2.1 and ASTM



A307 Grade C or A 36 and shall have a tensile strength of 58,000 psi (310 MPa) and a minimum bending yield strength of 45,000 psi (310 MPa). Bolt and threaded rod diameters shall be as specified in the applicable tables of this report.

**4.2.5 WS Wood Screws:** MiTek WS3 wood screws are provided with the PHD, PHDA, and UPHD series hold-downs. WS3-EXT screws with a proprietary corrosion-resistant finish are available on request for use where hot-dipped galvanized (HDG) finishes are required in accordance with the code. WS3 wood screws have a major diameter of 0.242 inch (6.1 mm), a length of 3.0 inches (76.2 mm), and a minimum bending yield strength of 180,000 psi (1240 MPa). WS15-GC wood screws with a proprietary corrosion-resistant finish are provided with DTB-TZ connectors. WS15-GC screws may be used where HDG finishes are required, in accordance with the code. WS15-GC wood screws have a major diameter of 0.242 inch (6.1 mm), a length of 1½ inches (38.1 mm), and a minimum bending yield strength of 180,000 psi (1,240 MPa). Additional information where required, is available in a current WS Screw certification report.

**4.2.6 Nails:** Nails used for connectors described in this report shall comply with material requirements, physical properties, tolerances, workmanship, protective coating and finishes, and packaging and package marking requirements specified in ASTM F1667; and shall have lengths, diameters, and bending yield strengths,  $F_{yb}$ , as shown in the following table:

FASTENER DESIGNATION	FASTENER LENGTH (inches)	SHANK DIAMETER (inch)	MINIMUM REQUIRED $F_{yb}$ (lbf/in <sup>2</sup> )
10d x 1½	1.5	0.148	90,000
10d common	3.0	0.148	90,000
16d common	3.5	0.162	90,000

For SI: 1 inch = 25.4 mm, 1 psi = 6.89 kPa.

**4.2.7 Use in Preservative and Fire-Retardant Treated Wood:** Connectors and fasteners used in contact with preservative-treated or fire-retardant-treated wood shall comply with Section 2304.10.6 of the 2021 IBC, Section 2304.10.5 of the 2018 and 2015 IBC, or Section R317.3 of the IRC. The lumber treater or the report holder (MiTek Inc.), or both, shall be contacted for recommendations on the appropriate level of corrosion resistance to specify for the connectors and fasteners as well as the connection capacities of the fasteners used with the specific proprietary preservative-treated or fire-retardant-treated wood.

### 5.0 IDENTIFICATION

The hold-down devices described in this report are identified by the product model (stock) number, the number of the IAPMO UES evaluation report (ER-200), and one or more of the following designations: MiTek, USP, or United Steel Products Company. Either IAPMO UES Marks of Conformity may also be used as shown below:

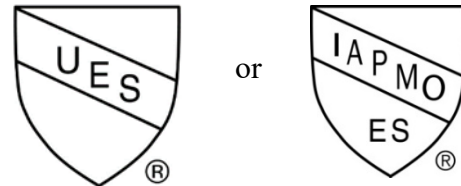

IAPMO UES ER-200

### 6.0 SUBSTANTIATING DATA

**6.1** Testing and analytical data submitted in accordance with the ICC-ES Acceptance Criteria for Hold-Downs, (Tie-Downs) Attached to Wood Members (AC155), approved May 2015, Editorially revised December 2020.

**6.2** Results of ASTM A90, ASTM B117, and ASTM G85 testing for the effects of weathering on proprietary exterior coated screws.

**6.3** Test reports are from laboratories in compliance with ISO/IEC 17025.

### 7.0 STATEMENT OF RECOGNITION

This evaluation report describes the results of research completed by IAPMO Uniform Evaluation Service on MiTek Hold-down and Tension-tie Connectors to assess conformance to the codes shown in Section 1.0 of this report and serves as documentation of the product certification. The connectors are manufactured at locations noted in Section 2.8 of this report under a quality assurance program with periodic inspections under the surveillance of IAPMO UES.

For additional information about this evaluation report please visit [www.uniform-es.org](http://www.uniform-es.org) or email us at [info@uniform-es.org](mailto:info@uniform-es.org)

TABLE 1 - DTB DECK TIE BRACKET HOLDDOWN

STOCK NUMBER	STEEL GAUGE	DIMENSIONS (inches)				FASTENER SCHEDULE					MINIMUM WOOD MEMBER THICKNESS (inches) <sup>6</sup>	ALLOWABLE LOADS (lbs) <sup>3,4</sup>		DEFLECTION AT ALLOWABLE DESIGN LOADS (inches)		STRENGTH LEVEL DEFORMATION $\Delta_s$ @ 160% (inches) <sup>5</sup>
						Bolt <sup>1</sup>		Screws <sup>2</sup>				100%	160%	$\Delta$ At 100%	$\Delta$ At 160%	
		Qty.	Type	Qty.	Size	Designation										
DTB-TZ	14	1 <sup>13</sup> / <sub>16</sub>	6	2 <sup>1</sup> / <sub>4</sub>	1 <sup>1</sup> / <sub>6</sub>	1	1/2	8	1/4" x 1 <sup>1</sup> / <sub>2</sub> "	WS15	1 <sup>1</sup> / <sub>2</sub>	1835	1835	0.119	0.119	0.245

For SI: 1 inch = 25.4 mm, 1 lbf = 4.45 N, 1 psi = 6.89 kPa

<sup>1</sup>Minimum ASTM A307 bolt or threaded rod with cut washer and hex nut.

<sup>2</sup>WS15 denotes USP Wood Screw, 1/4 inch diameter 1 1/2 inch long.

<sup>3</sup>Allowable loads include a 60% duration of load increase for wind or seismic load conditions. No further increase shall be permitted.

<sup>4</sup>Allowable load values of the holdown (tie-down) device are a measure of the strength of the assembly with a safety factor of 3.0 applied to the lowest maximum test load.

<sup>5</sup>The design of holddown (tie-down) devices used in series shall account for the cumulative deformation of all holdowns (tie-downs) within said series.

<sup>6</sup>The design of the framing member is outside the scope of this report. The structural designer shall select a framing member sized to prevent fasteners from splitting the wood and of adequate strength properties to resist the anticipated loads in accordance with Section 4.1.1 of this report. Figure 7 lists the nearest fastener hole distance so required fastener end and edge distance, per ESR-2761, can be provided. Minimum width shall be 3 1/2 inches.

<sup>7</sup>Tabulated allowable loads shall be multiplied by 1.4 to obtain the strength or LRFD level loads corresponding to the tabulated strength level deformation  $\Delta_s$ .

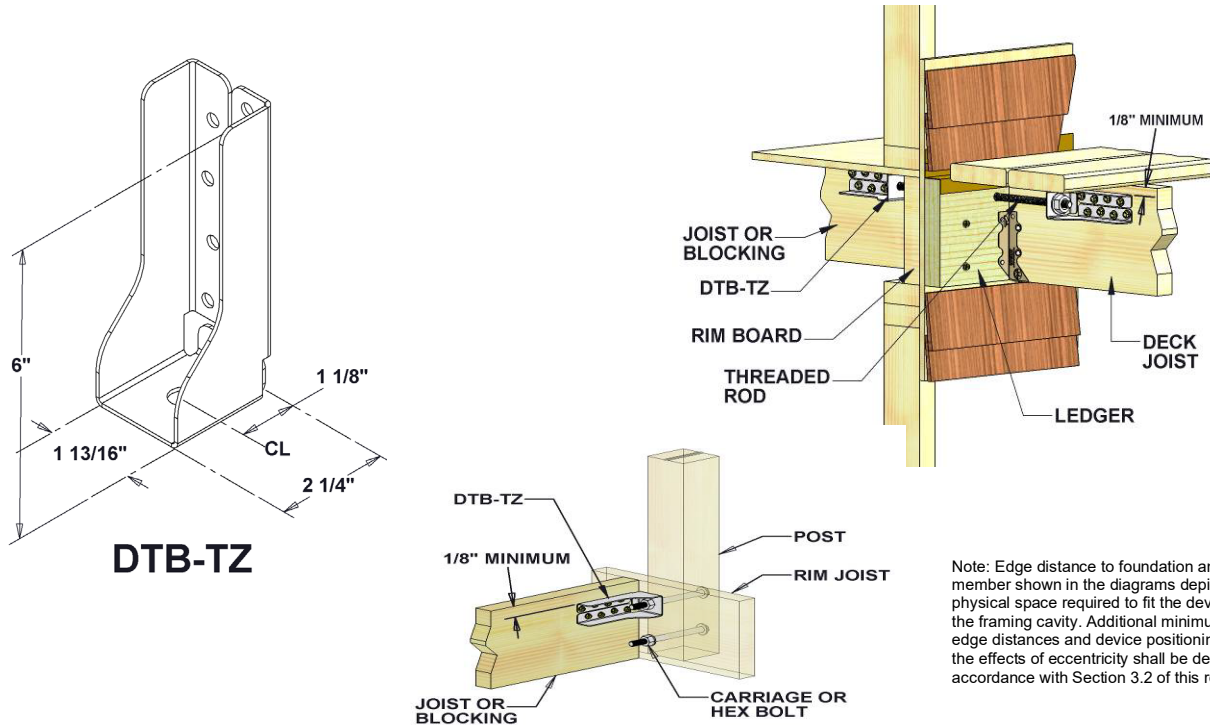

FIGURE 1 – DTB-TZ DECK TIE BRACKET CONNECTOR

TABLE 3 - LTS and LTTI TENSION TIE HOLDOWN SERIES

STOCK NUMBER	STEEL GAGE		DIMENSIONS (inches)				FASTENER SCHEDULE <sup>1,2,3</sup>							MINIMUM WOOD MEMBER THICKNESS (inches) <sup>9</sup>	ALLOWABLE LOADS (lbs) <sup>4,7</sup>		DEFLECTION AT ALLOWABLE DESIGN LOADS (inches)	STRENGTH LEVEL DEFORMATION $\Delta_s$ (inches) <sup>8</sup>
	Strap	Plate	W	L	D	CL	Anchor Bolts <sup>5</sup>		Nails		Bolts				For Nailed Configuration	For Bolted Configuration <sup>6</sup>		
							Qty.	Type	Spacing	Qty.	Type	Qty.	Diameter (inches)					
LTS19	16	3	1 <sup>3</sup> / <sub>4</sub>	22 <sup>1</sup> / <sub>4</sub>	3	1 <sup>1</sup> / <sub>2</sub>	1	3 <sup>3</sup> / <sub>4</sub>	2 <sup>1</sup> / <sub>2</sub>	8	10dC	--	--	3	1205	--	0.132	0.206
LTS20	12	3	2	20	3	1 <sup>1</sup> / <sub>2</sub>	1	1 <sup>1</sup> / <sub>2</sub>	3 <sup>3</sup> / <sub>4</sub>	10	10d x 11/2" 16dC	--	--	1 <sup>1</sup> / <sub>2</sub> 3	1100 1105	--	0.060 0.064	0.231 0.245
LTS20B	12	3	2	20	3	1 <sup>1</sup> / <sub>2</sub>	1	3 <sup>3</sup> / <sub>4</sub>	3 <sup>3</sup> / <sub>4</sub>	10	10d x 11/2" 16dC	2	1 <sup>1</sup> / <sub>2</sub>	1 <sup>1</sup> / <sub>2</sub> 3	1100 1105	1175	0.128	0.234
LTTI31	18	3	3 <sup>3</sup> / <sub>4</sub>	31	2 <sup>5</sup> / <sub>8</sub>	1 <sup>3</sup> / <sub>8</sub>	1	5 <sup>5</sup> / <sub>8</sub>	3	18	10d x 11/2"	--	--	1 <sup>1</sup> / <sub>2</sub>	2805	--	0.175	0.234

For SI: 1 inch = 25.4 mm, 1 lbf = 4.45 N, 1 psi = 6.89 kPa

<sup>1</sup>A 10d x 1<sup>1</sup>/<sub>2</sub>" nail is 1<sup>1</sup>/<sub>2</sub> inches long and 0.148 inches in diameter.

<sup>2</sup>A 10d Common nail is 3 inches long and 0.148 inches in diameter.

<sup>3</sup>A 16d Common nail is 3<sup>1</sup>/<sub>2</sub> inches long and 0.162 inches in diameter.

<sup>4</sup>Allowable loads include a 60% duration of load increase for wind or seismic load conditions. No further increase shall be permitted.

<sup>5</sup>The designer must specify anchor bolt type, nut, washer, length and embedment depth.

<sup>6</sup>Bolts connecting the LTS20B require a minimum length of 1<sup>1</sup>/<sub>2</sub> inches in vertical member for listed load.

<sup>7</sup>Allowable load values of the holdown (tie-down) device are a measure of the strength of the assembly with a safety factor of 3.0 applied to the lowest maximum test load.

<sup>8</sup>The design of holdown (tie-down) devices used in series shall account for the cumulative deformation of all holdowns (tie-downs) within said series.

<sup>9</sup>The design of the framing member is outside the scope of this report. The structural designer shall select a framing member sized to prevent fasteners from splitting the wood and of adequate strength properties, to resist the anticipated loads in accordance with Section 4.1.1 of this report.

Figure 7 lists the nearest fastener hole distance so required fastener end and edge distance, per NDS, can be provided.

Minimum width shall be 3<sup>1</sup>/<sub>2</sub> inches for the LTS series and 4 inches for the LTTI31.

<sup>10</sup>Tabulated allowable loads shall be multiplied by 1.4 to obtain the strength or LRFD level loads corresponding to the tabulated strength level deformation  $\Delta_s$ .

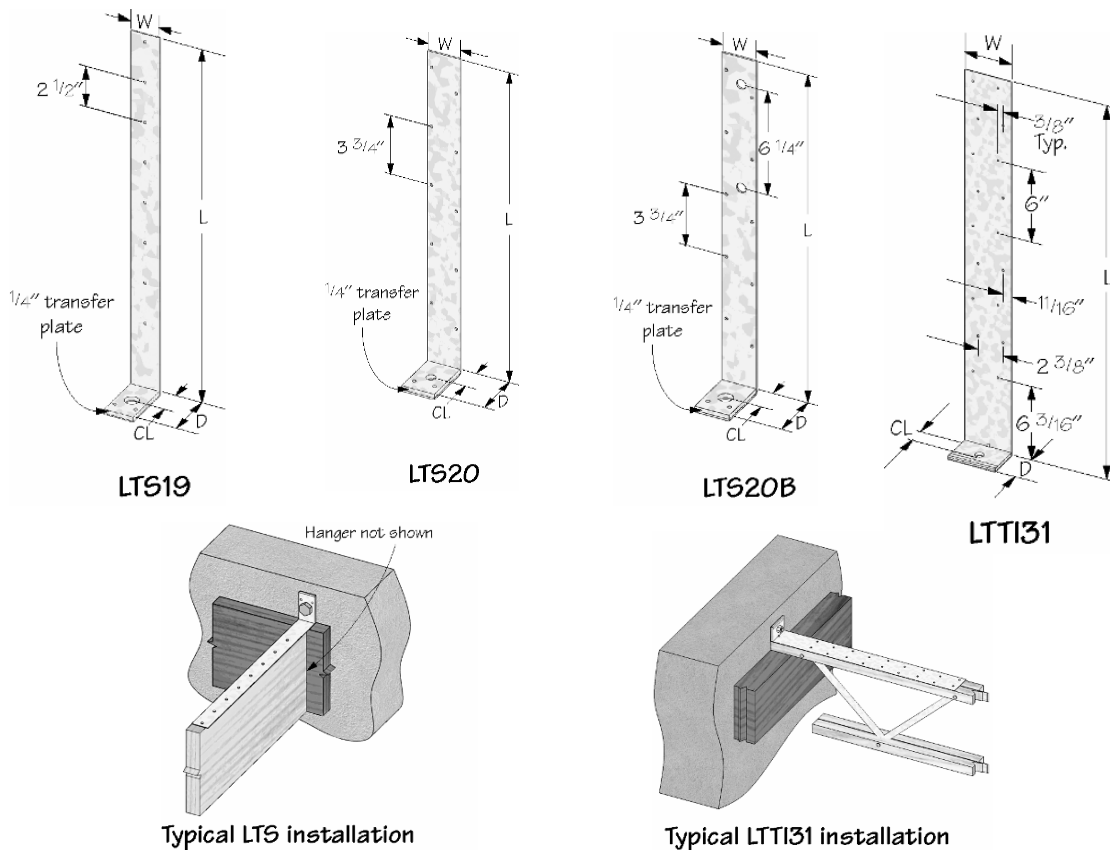

FIGURE 3 – LTS and LTTI TENSION TIE CONNECTORS

TABLE 4 - PHD & PHDA HOLD-DOWN SERIES

STOCK NUMBER	STEEL GAGE	DIMENSIONS (inches)				FASTENER SCHEDULE				MINIMUM WOOD MEMBER THICKNESS (inches) <sup>6</sup>	ALLOWABLE LOADS (lbs) <sup>2,3</sup>	DEFLECTION AT ALLOWABLE DESIGN LOADS (inches)	STRENGTH LEVEL DEFORMATION (inches) <sup>4</sup>
		W	H	D	CL	Anchor Bolts <sup>5</sup>		Wood Screws <sup>1</sup>					
						Qty.	Dia (in)	Qty.	Type				
PHD2	12	3 1/4	7 1/2	3	1 3/8	1	3/8	10	WS3	3	4,815	0.058	0.096
PHD5	12	3 1/4	10 1/8	3	1 3/8	1	3/8	14	WS3	3	5,540	0.056	0.085
PHD6	12	3 1/4	13 1/16	3	1 3/8	1	3/8	18	WS3	3	7,295	0.061	0.105
PHD8	12	3 1/4	16 1/2	3	1 3/8	1	3/8	24	WS3	3	8,185	0.062	0.111
PHD2A	14	3 1/4	7 3/4	2 3/8	1 3/8	1	3/8	6	WS3	3	3,215	0.155	0.191
PHD4A	14	3 1/4	9 1/4	2 3/8	1 3/8	1	3/8	10	WS3	3	5,215	0.137	0.177
PHD5A	14	3 1/4	11 1/16	2 3/8	1 3/8	1	3/8	14	WS3	3	6,525	0.135	0.177
PHD8A	10	3 1/4	15 1/2	2 3/8	1 3/8	1	3/8	20	WS3	3	8,540	0.079	0.110

For SI: 1 inch = 25.4 mm, 1 lbf = 4.45 N, 1 psi = 6.89 kPa

<sup>1</sup>WS3 denotes USP Wood Screw, 1/4 inch diameter 3 inches long

<sup>2</sup>Allowable loads include a 60% duration of load increase for wind or seismic load conditions. No further increase shall be permitted.

<sup>3</sup>Allowable load values of the hold-down (tie-down) device are a measure of the strength of the assembly with a safety factor of 3.0 applied to the lowest maximum test load.

<sup>4</sup>The design of hold-down (tie-down) devices used in series shall account for the cumulative deformation of all hold-downs (tie-downs) within said series.

<sup>5</sup>The designer must specify anchor bolt type, nut, washer, length and embedment depth.

<sup>6</sup>The design of the framing member is outside the scope of this report. The structural designer shall select a framing member sized to prevent fasteners from splitting the wood and of adequate strength properties to resist the anticipated loads in accordance with Section 4.1.1 of this report. Figure 7 lists the nearest fastener hole distance so required fastener end and edge distance, per ESR-2761, can be provided. Minimum width shall be 3 1/2 inches.

<sup>7</sup>Tabulated allowable loads shall be multiplied by 1.4 to obtain the strength or LRFD level loads corresponding to the tabulated strength level deformation  $\Delta_s$ .

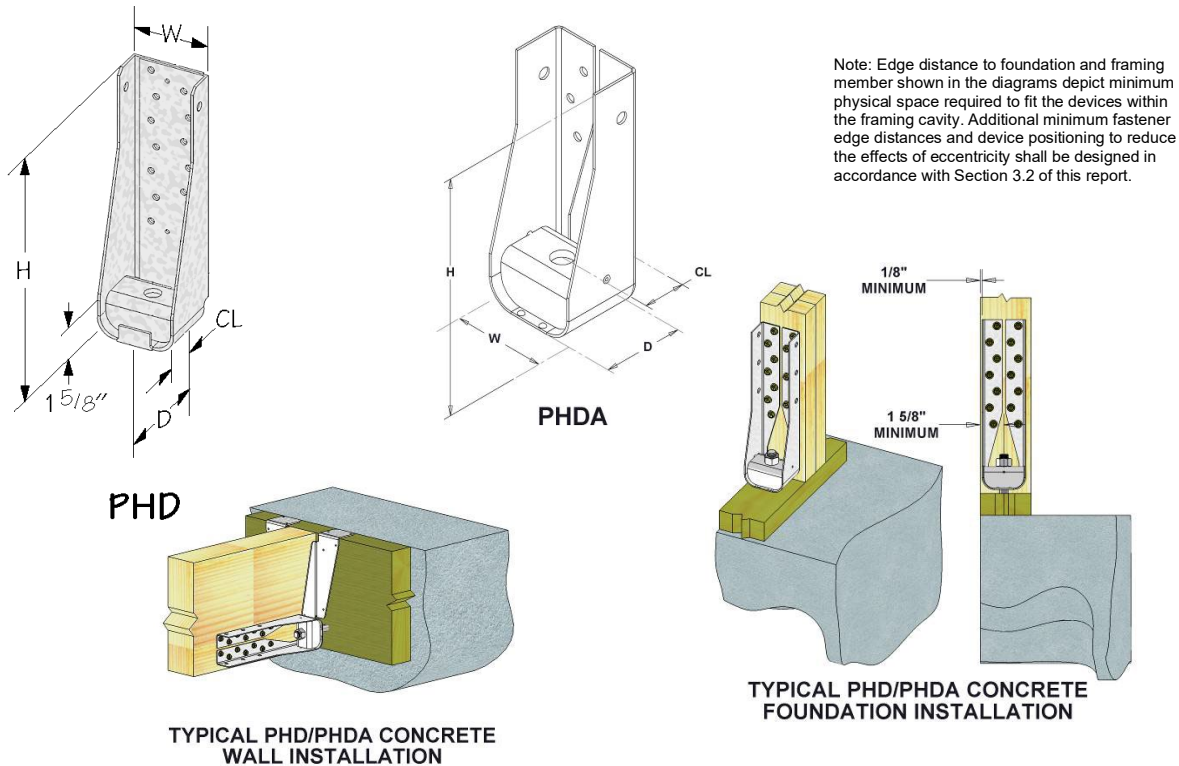

FIGURE 4 – PHD AND PHDA HOLD-DOWNS AND CONNECTORS

TABLE 5 - UPHD HOLD-DOWN SERIES

STOCK NUMBER	STEEL GAGE	DIMENSIONS (inches)				FASTENER SCHEDULE				MINIMUM WOOD MEMBER THICKNESS (inches) <sup>6</sup>	ALLOWABLE LOADS (lbs) <sup>2,3</sup>	DEFLECTION AT ALLOWABLE DESIGN LOADS (inches)	STRENGTH LEVEL DEFORMATION (inches) <sup>4</sup>
		W	H	D	CL	Anchor Bolts <sup>5</sup>		Wood Screws <sup>1</sup>					
						Qty.	Dia (in)	Qty.	Type				
UPHD8	10	3 1/4	17 1/4	3 1/2	1 7/8	1	1/2	24	WS3	3.5	9,165	0.075	0.100
UPHD9	10	3 1/4	17 1/4	3 1/2	1 1/2	1	1	24	WS3	5.5	11,270	0.057	0.077
UPHD11	7	3	15 1/8	3 1/2	1 1/2	1	1	24	WS3	5.5	14,395	0.077	0.106
UPHD14	7	3	18 1/4	3 1/2	1 1/2	1	1	30	WS3	5.5	16,695	0.082	0.109

For SI: 1 inch = 25.4 mm, 1 lbf = 4.45 N, 1 psi = 6.89 kPa

<sup>1</sup>WS3 denotes USP Wood Screw, 1/4 inch diameter 3 inches long

<sup>2</sup>Allowable loads include a 60% duration of load increase for wind or seismic load conditions. No further increase shall be permitted.

<sup>3</sup>Allowable load values of the hold-down (tie-down) device are a measure of the strength of the assembly with a safety factor of 3.0 applied to the lowest maximum test load.

<sup>4</sup>The design of hold-down (tie-down) devices used in series shall account for the cumulative deformation of all hold-downs (tie-downs) within said series.

<sup>5</sup>The designer must specify anchor bolt type, nut, washer, length and embedment depth.

<sup>6</sup>The design of the framing member is outside the scope of this report. The structural designer shall select a framing member sized to prevent fasteners from splitting the wood and of adequate strength properties to resist the anticipated loads in accordance with Section 4.1.1 of this report. Figure 7 lists the nearest fastener hole distance so required fastener end and edge distance, per ESR-2761, can be provided.

Minimum width shall be 3 1/2 inches for the UPHD8 and 5 1/2 inches for the UPHD9, UPHD11 and UPHD14.

<sup>7</sup>Tabulated allowable loads shall be multiplied by 1.4 to obtain the strength or LRFD level loads corresponding to the tabulated strength level deformation Δs.

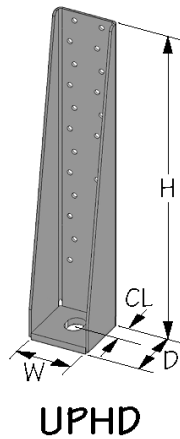

Note: Edge distance to foundation and framing member shown in the diagrams depict minimum physical space required to fit the devices within the framing cavity. Additional minimum fastener edge distances and device positioning to reduce the effects of eccentricity shall be designed in accordance with Section 3.2 of this report.

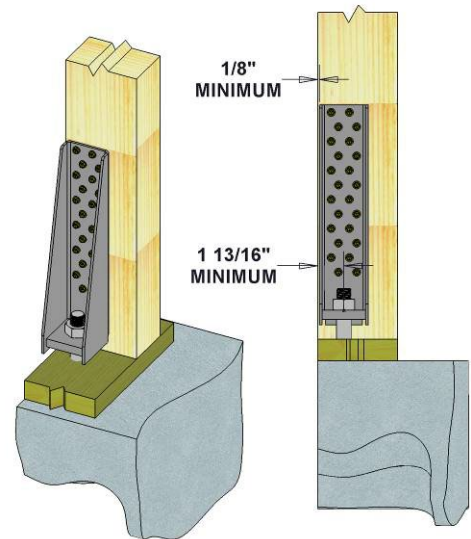
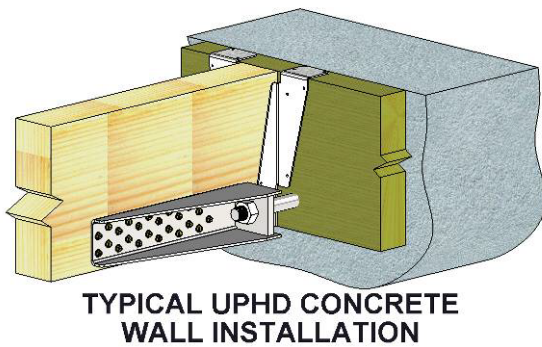

FIGURE 5 - UPHD HOLD-DOWNS AND CONNECTORS





TABLE 6 - TDX & TD Holddown Series

STOCK NUMBER	STEEL GAGE	DIMENSIONS (inches)				FASTENER SCHEDULE					LENGTH OF BOLT IN VERTICAL MEMBER (inches) <sup>5</sup>	ALLOWABLE LOADS (lbs) <sup>2,3</sup>	DEFLECTION AT ALLOWABLE DESIGN LOADS (inches)	STRENGTH LEVEL DEFORMATION $\Delta_s$ (in) <sup>4</sup>
						Anchor Bolts <sup>5</sup>		Bolts <sup>1</sup>						
		W	H	D	CL	Qty.	Type	Min. End Distance	Qty.	Type		160%	$\Delta$ At 160%	
TDX2	12	2 <sup>1</sup> / <sub>16</sub>	8 <sup>1</sup> / <sub>8</sub>	2 <sup>3</sup> / <sub>4</sub>	1 <sup>1</sup> / <sub>2</sub>	1	5 <sup>5</sup> / <sub>8</sub>	4 <sup>1</sup> / <sub>2</sub>	2	5 <sup>5</sup> / <sub>8</sub>	1 <sup>1</sup> / <sub>2</sub>	1910	0.150	0.186
											3	2345	0.167	0.218
											3 <sup>1</sup> / <sub>2</sub>	3130	0.140	0.196
											5 <sup>1</sup> / <sub>2</sub>	3130	0.140	0.196
TD5	7	3	6 <sup>3</sup> / <sub>8</sub>	3 <sup>3</sup> / <sub>4</sub>	2 <sup>1</sup> / <sub>8</sub>	1	3 <sup>3</sup> / <sub>4</sub>	5 <sup>1</sup> / <sub>4</sub>	2	3 <sup>3</sup> / <sub>4</sub>	1 <sup>1</sup> / <sub>2</sub>	2405	0.122	0.160
											3	4040	0.140	0.246
											3 <sup>1</sup> / <sub>2</sub>	4040	0.140	0.246
											5 <sup>1</sup> / <sub>2</sub>	4040	0.140	0.246
TD7	3	3 <sup>3</sup> / <sub>8</sub>	11 <sup>7</sup> / <sub>8</sub>	3 <sup>5</sup> / <sub>8</sub>	2 <sup>1</sup> / <sub>8</sub>	1	1 <sup>1</sup> / <sub>8</sub>	6 <sup>1</sup> / <sub>8</sub>	3	7 <sup>7</sup> / <sub>8</sub>	1 <sup>1</sup> / <sub>2</sub>	4600	0.095	0.117
											3	8195	0.125	0.165
											3 <sup>1</sup> / <sub>2</sub>	9420	0.139	0.188
											5 <sup>1</sup> / <sub>2</sub>	10510	0.152	0.213
TD9	3	3 <sup>3</sup> / <sub>8</sub>	16 <sup>1</sup> / <sub>2</sub>	4 <sup>1</sup> / <sub>4</sub>	2 <sup>1</sup> / <sub>8</sub>	1	1 <sup>1</sup> / <sub>8</sub>	7	3	1	3	9330	0.146	0.184
											3 <sup>1</sup> / <sub>2</sub>	10715	0.160	0.208
											4 <sup>1</sup> / <sub>2</sub>	13370	0.169	0.225
											5 <sup>1</sup> / <sub>2</sub>	13500	0.170	0.227
TD12	3	3 <sup>1</sup> / <sub>2</sub>	20 <sup>1</sup> / <sub>2</sub>	4 <sup>1</sup> / <sub>4</sub>	2 <sup>1</sup> / <sub>8</sub>	1	1 <sup>1</sup> / <sub>8</sub>	7	4	1	3	12070	0.132	0.160
											3 <sup>1</sup> / <sub>2</sub>	13960	0.142	0.178
											4 <sup>1</sup> / <sub>2</sub>	16550	0.185	0.240
											5 <sup>1</sup> / <sub>2</sub>	16550	0.185	0.240
TD15	3	3 <sup>1</sup> / <sub>2</sub>	25	4 <sup>3</sup> / <sub>8</sub>	2 <sup>1</sup> / <sub>8</sub>	1	1 <sup>1</sup> / <sub>4</sub>	7	5	1	3	14505	0.167	0.195
											3 <sup>1</sup> / <sub>2</sub>	16945	0.178	0.213
											4 <sup>1</sup> / <sub>2</sub>	17755	0.202	0.239
											5 <sup>1</sup> / <sub>2</sub>	17755	0.202	0.239

For SI: 1 inch = 25.4 mm, 1 lbf = 4.45 N, 1 psi = 6.89 kPa

<sup>1</sup> Bolts shall conform to ASTM A307 Grade A or better.

<sup>2</sup> Allowable loads include a 60% duration of load increase for wind or seismic load conditions. No further increase shall be permitted.

<sup>3</sup> Allowable load values of the holddown (tie-down) device are a measure of the strength of the assembly with a safety factor of 3.0 applied to the lowest maximum test load.

<sup>4</sup> The design of holddown (tie-down) devices used in series shall account for the cumulative deformation of all holddowns (tie-downs) within said series.

<sup>5</sup> The designer must specify anchor bolt type, nut, washer, length and embedment depth.

<sup>6</sup> The design of the framing member is outside the scope of this report. The structural designer shall select a framing member sized to prevent fasteners from splitting the wood and of adequate strength properties to resist the anticipated loads in accordance with Section 4.1.1 of this report. The location of the holddown on the post shall comply with Figure 6 of this report. Minimum member size and grade for each model number shall equal or exceed sizes provided in Table 6A.

<sup>7</sup> Tabulated allowable loads shall be multiplied by 1.4 to obtain the strength or LRFD level loads corresponding to the tabulated strength level deformation  $\Delta_s$ .

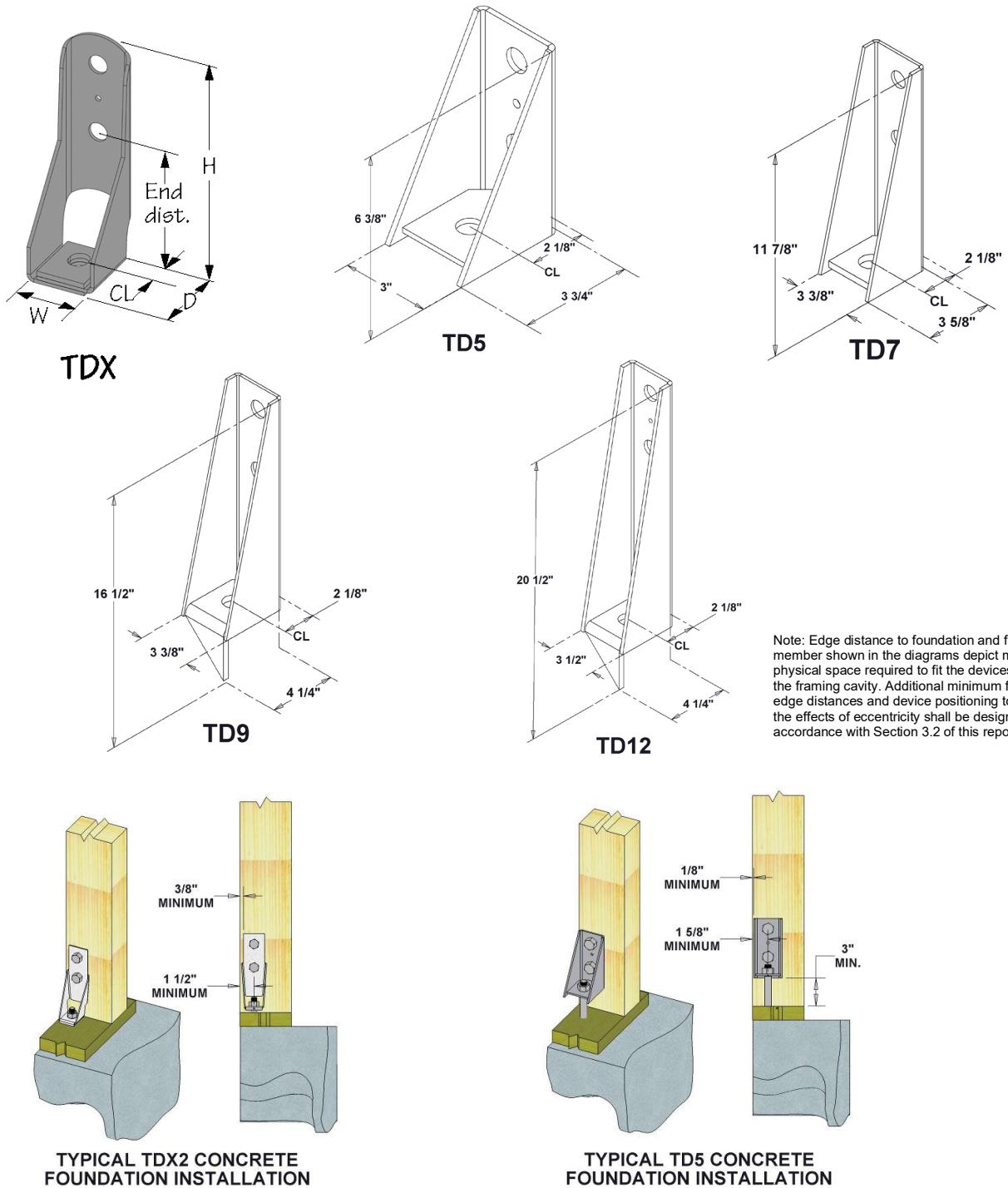

Note: Edge distance to foundation and framing member shown in the diagrams depict minimum physical space required to fit the devices within the framing cavity. Additional minimum fastener edge distances and device positioning to reduce the effects of eccentricity shall be designed in accordance with Section 3.2 of this report.

**FIGURE 6 – TD AND TDX HOLD-DOWNS**

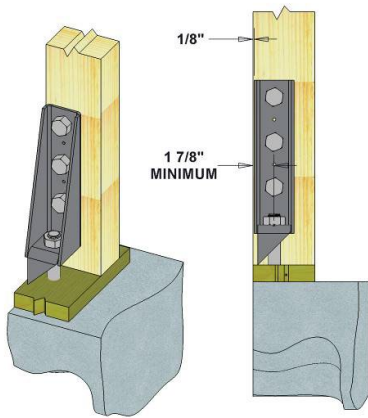

**TYPICAL TD9 CONCRETE FOUNDATION INSTALLATION (TD12 & TD15 SIMILAR)**

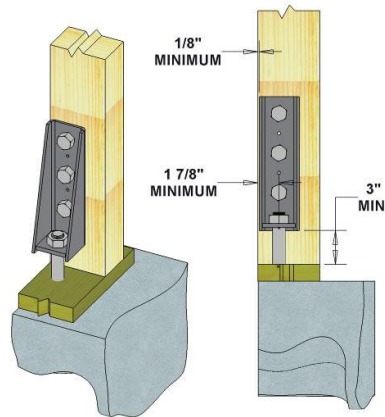

**TYPICAL TD7 CONCRETE FOUNDATION INSTALLATION**

Note: Edge distance to foundation and framing member shown in the diagrams depict minimum physical space required to fit the devices within the framing cavity. Additional minimum fastener edge distances and device positioning to reduce the effects of eccentricity shall be designed in accordance with Section 3.2 of this report.

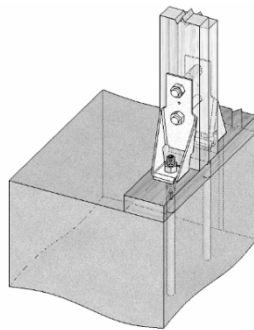

**Typical TDX2 back-to-back installation**

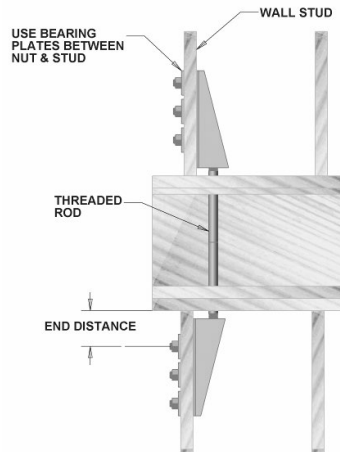

**HOLD-DOWN INSTALLATION BETWEEN FLOORS**

**FIGURE 6 (Continued) – TD AND TDX HOLD-DOWNS**



**TABLE 6A – Matrix of Acceptable Grades of Douglas-Fir Larch Framing for Use with TDX and TD Hold-downs, Based on Member Size and Number of Plies <sup>2</sup>**

STOCK NUMBER	Vertical Member Thickness (in)	Stud or Timber Size	No. of Plies	Commercial Grade				
				Stud	No. 2	No. 1	No.1 & Btr	Select Str.
TDX2	1 1/2	2x4	1					
	3	2x4	2					
	3 1/2	4x4	1					
	5 1/2	4x6	1					
TD5	1 1/2	2x4	1					
	3	2x4	2					
	3 1/2	4x4	1					
	5 1/2	4x6	1					
TD7	1 1/2	2x6	1					
	3	2x6	2					
	3 1/2	4x6	1					
	5 1/2	4x6	1	--				
TD9	3	2x6	2					
	3 1/2	4x6	1					
	4 1/2	2x6	3					
	5 1/2	6x6	1	--	--			
TD12	3	2x6	2	--				
	3 1/2	4x6	1	--				
	4 1/2	2x6	3	--				
	5 1/2	6x6	1	--				
TD15	3	2x6	2	--	--	--		
	3 1/2	4x6	1	--	--	--		
	4 1/2	2x6	3	--				
	5 1/2	6x6	1	--				

<sup>1</sup>To achieve the allowable loads listed in TABLE 6 (above), acceptable solutions to framing member sizes are indicated thus.

<sup>2</sup>Analysis based on 2018 Edition of the AF&PA National Design Specification for Wood Construction Appendix E



TABLE 7 - STEEL, TYPE, STRENGTH, AND CORROSION RESISTANCE

PRODUCT	Welded <sup>1</sup>	PART	STEEL GAGE	STEEL SPECIFICATION	SPECIFIED YIELD STRENGTH (lb <sub>f</sub> /in <sup>2</sup> )	SPECIFIED TENSILE STRENGTH (lb <sub>f</sub> /in <sup>2</sup> )	COATING
DTB-TZ		Body	14	ASTM A653, SS designation Grade 40S	42,000	56,000	G-185 <sup>2</sup>
HTT		Body	12	ASTM A653, SS designation Grade 40S	42,000	56,000	G90 <sup>2</sup>
LTS19		Strap	16	ASTM A653, SS designation Grade 40S	42,000	56,000	G90 <sup>2</sup>
		Washer	3	ASTM A36	36,000	58,000	Painted
LTS20B		Strap	12	ASTM A653, SS designation Grade 40S	42,000	56,000	G90 <sup>2</sup>
		Washer	3	ASTM A36	36,000	58,000	Painted
LTTI31		Strap	18	ASTM A653, SS designation Grade 40S	42,000	56,000	G90 <sup>2</sup>
		Plate	3	ASTM A36	36,000	58,000	Painted
PHD		Body	12	ASTM A653, SS designation Grade 40S	42,000	56,000	G90 <sup>2</sup>
		Washer	3	ASTM A36	36,000	58,000	Painted
PHDA		Body	14	ASTM A653, SS designation Grade 40S	42,000	56,000	G90 <sup>2</sup>
		Washer	3	ASTM A36	36,000	58,000	Painted
UPHD8	X	Body	10	ASTM A1011, designation, Grade 33	33,000	45,000	Painted
		Base Plate	1/2" Steel Plate	ASTM A36	36,000	58,000	Painted
UPHD9	X	Body	10	ASTM A1011, designation, Grade 33	33,000	45,000	Painted
		Base Plate	5/8" Steel Plate	ASTM A36	36,000	58,000	Painted
UPHD11 and UPHD14	X	Body	7	ASTM A1011, designation, Grade 33	33,000	45,000	Painted
		Base Plate	5/8" Steel Plate	ASTM A36	36,000	58,000	Painted
TD5	X	Body	7	ASTM A1011, designation, Grade 33	33,000	45,000	Painted
		Base Plate	7	ASTM A1011, designation, Grade 33	33,000	45,000	Painted
TD7, TD9 TD12 and TD15	X	Body	3	ASTM A36	36,000	58,000	Painted
		Base Plate	3/8" Steel Plate	ASTM A36	36,000	58,000	Painted
TDX2-TZ		Body	12	ASTM A653, SS designation Grade 40S	42,000	56,000	G-185
		Washer	10	ASTM A653, SS designation Grade 33	33,000	45,000	G90 <sup>2</sup>

For **SI**: 1 inch = 25.4 mm, 1 psi = 6.89 kPa.

<sup>1</sup> Products are factory welded at the MiTek manufacturing facilities in Largo, FL; Tolleson, AZ, and Montgomery, MN under a quality control program with inspections by IAPMO Uniform ES.

<sup>2</sup> Corrosion protection is a zinc coating of sheet steel in accordance with ASTM A 653.

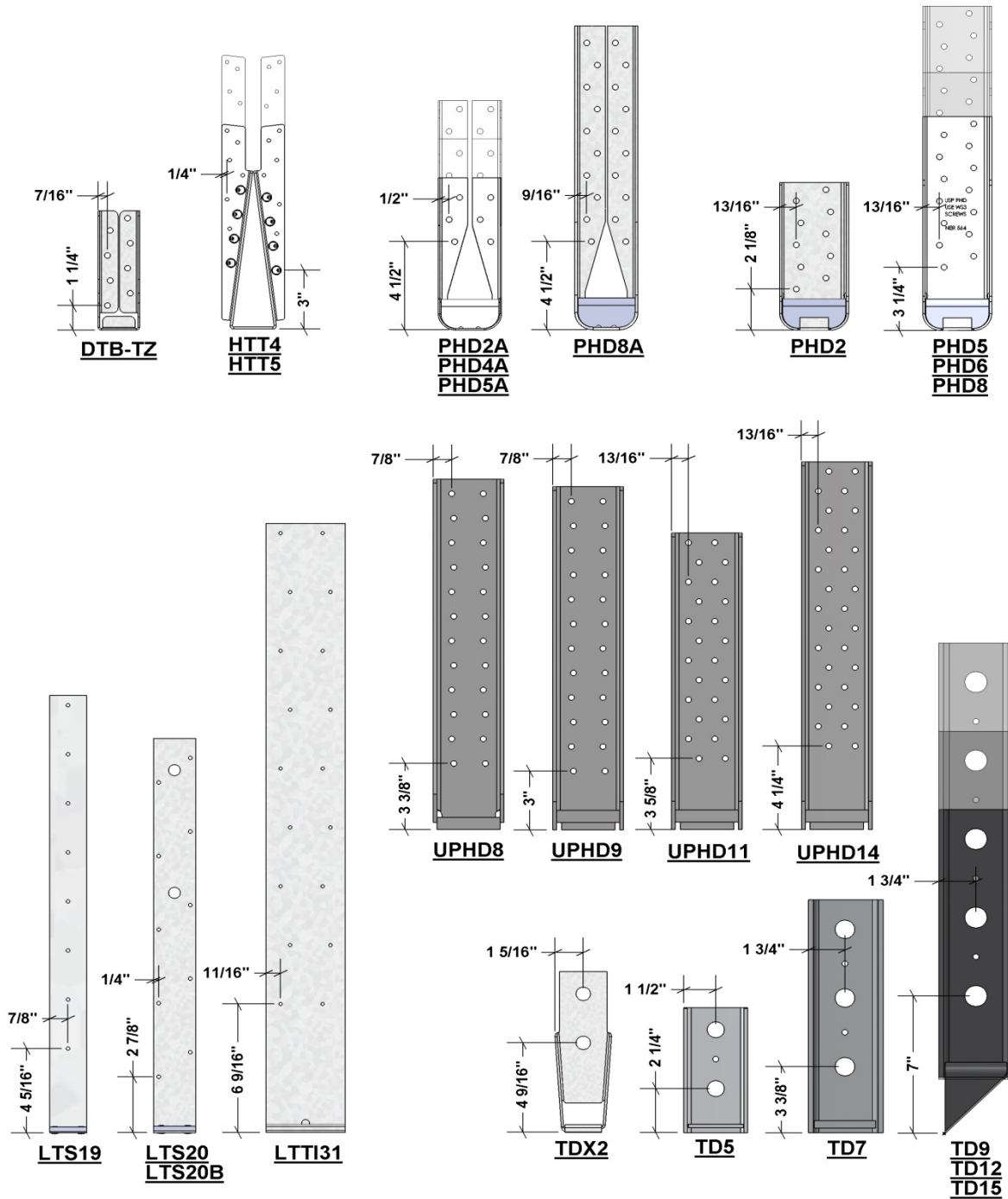

FIGURE 7 – DETAILS OF RECOGNIZED PRODUCTS SHOWING FASTENER LOCATIONS



## FLORIDA SUPPLEMENT

**MITEK INC.**  
**16023 Swingley Ridge Rd.**  
**Chesterfield, MO 63017**  
**800-328-5934**

[www.mitek-us.com](http://www.mitek-us.com)  
[uspcustomerservice@mii.com](mailto:uspcustomerservice@mii.com)

## MITEK HOLD-DOWN AND TENSION-TIE CONNECTORS

### CSI Section:

**06 05 23 Wood, Plastic and Composite Fastenings**

### 1.0 RECOGNITION

The MiTek Inc. Hold-down and Tension-tie Connectors recognized in this report have been evaluated for use as wood framing anchorage. The structural performance properties of the connectors comply with the intent of the provisions of the following codes and regulations:

- 2023 and 2020 Florida Building Code<sup>®</sup>, Building (FBC, Building)
- 2023 and 2020 Florida Building Code<sup>®</sup>, Residential (FBC, Residential)

### 2.0 LIMITATIONS

Use of the MiTek Hold-down and Tension-tie Connectors recognized in ER-200 and this supplement is subject to the requirements of ER-200 and the following limitations:

**2.1** The connectors shall be manufactured, identified, and installed in accordance with ER-200 and the manufacturer's published installation instructions. Where conflicts occur, the more restrictive shall govern. A copy of the manufacturer's published installation instructions shall be available at the job site during installation.

**2.2** Design requirements shall be determined in accordance with the applicable code. Load combinations shall be in accordance with Sections 1605.1 or 1605.2 of the 2023 FBC, Building, or Sections 1605.2 or 1605.3 of the 2020 FBC, Building, as applicable.

**2.3** For use under the 2023 FBC, Building and 2023 FBC, Residential, design and installation shall be in accordance with the provisions noted in ER-200 for the 2021 IBC or 2021 IRC, as applicable, unless otherwise noted in this supplement.

**2.4** For use under the 2020 FBC, Building and 2020 FBC, Residential, design and installation shall be in accordance with the provisions noted in ER-200 for the 2018 IBC or 2018 IRC, as applicable, unless otherwise noted in this supplement.

**2.5** Design wind loads shall be in accordance with Section 1609.1.1 of the FBC, Building or Section R301.2.1.1 of the FBC, Residential, as applicable, and Section 1620 of the FBC, Building where used in High-velocity Hurricane Zones (HVHZ).

**2.6** Use of MiTek Hold-down and Tension-tie Connectors recognized in this supplement shall comply with Chapter 23 of the FBC, Building, and FBC, Residential, as applicable. The hold-downs and connectors were tested in accordance with ASTM D7147, as required by FBC, Building Section 2304.10.3.

**2.7** The hold-downs and connectors shall be corrosion resistant or shall be provided with corrosion protection in accordance with Section 2324.2 of the FBC, Building or R317.3 of the FBC, Residential, and approved by the building official. The report holder (MiTek Inc.) shall be contacted for recommendations on the appropriate level of corrosion resistance for the applicable weather conditions and for use with wood treatment chemicals.

**2.8** The use of MiTek Hold-down and Tension-tie Connectors recognized in this report supplement complies with the High-velocity Hurricane Zone (HVHZ) provisions set forth in Section 2122.7 of the FBC, Building. Where used in accordance with Section 2122.7.2 of FBC, Building, the connectors shall be designed to provide a positive direct connection to resist the horizontal forces as required in Section 1620 (HVHZ) of the FBC, Building or 200 pounds per lineal foot (2919 N/m), whichever is greater, in accordance with FBC, Building Section 2122.7.3.

**2.9** The use of MiTek Hold-down and Tension-tie Connectors recognized in this report supplement complies with the High-velocity Hurricane Zone (HVHZ) provisions set forth in Section 2324.2 of the FBC, Building. Where used in accordance with Section 2321.6 of FBC, Building, the structural angles, clips, and ties shall be designed to resist the uplift forces as required in Section 1620 (HVHZ) of the FBC, Building or 700 pounds (3114 N), whichever is greater, in accordance with FBC, Building Section 2321.7.

**2.10** Connection shall be in accordance with FBC, Building Section 2321.5 for wood-to-concrete anchorage, and FBC, Building Section 2321.6 for wood-to-wood anchorage.

**2.11** For products falling under Section (5)(d) of Florida Rule 61G20-2, verification that the report holder's quality assurance program is audited by a quality assurance entity approved by the Florida Building Commission (or the building official where the report holder does not possess an approval by the Commission) is required to provide oversight and determine that the products are being manufactured as described in this evaluation report and supplement to establish continual product performance.

**2.12** This supplement expires concurrently with ER-200.

For additional information about this evaluation report please visit [www.uniform-es.org](http://www.uniform-es.org) or email us at [info@uniform-es.org](mailto:info@uniform-es.org)



## CITY OF LOS ANGELES SUPPLEMENT

**MITEK INC.**  
**16023 Swingley Ridge Rd.**  
**Chesterfield, MO 63017**  
**800-328-5934**  
[www.mitek-us.com](http://www.mitek-us.com)  
[uscustomerservice@mii.com](mailto:uscustomerservice@mii.com)

### MITEK HOLD-DOWN AND TENSION-TIE CONNECTORS

**CSI Section:**  
**06 05 23 Wood, Plastic and Composite Fastenings**

#### 1.0 RECOGNITION

The MiTek Inc. Hold-down and Tension-tie Connectors as evaluated and represented in IAPMO UES Evaluation Report ER-200 and with changes as noted in this supplement are a satisfactory alternative for use in buildings built under the following codes (and regulations):

- 2023 City of Los Angeles Building Code (LABC)
- 2023 City of Los Angeles Residential Code (LARC)

#### 2.0 LIMITATIONS

Use of the MiTek Hold-down and Tension-tie Connectors recognized in ER-200 and this supplement is subject to the requirements of ER-200 and the following limitations:

**2.1** The connectors shall be manufactured, identified, and installed in accordance with ER-200 and the manufacturer's published installation instructions. Where conflicts occur, the more restrictive shall govern. A copy of the manufacturer's published installation instructions shall be available at the job site during installation.

**2.2** The design, installation, and inspection of the MiTek Hold-down and Tension-tie Connectors shall be in accordance with LABC Chapters 16 and 17, as applicable, due to local amendments to these chapters.

**2.3** Design and installation shall be in accordance with the provisions noted in ER-200 for the 2021 IBC or 2021 IRC, as applicable, unless otherwise noted in this supplement.

**2.4** The calculations shall be prepared, stamped, and signed by a California registered design professional.

**2.5** Hold-down connectors shall comply with LABC Section 2305.5 and be designed to resist shear wall overturning moments using 75 percent of the allowable load values shown in Tables 4, 5, and 6 of ER-200.

**2.6** Connections shall be in accordance with LABC Section 2321.5 for wood-to-concrete anchorage, and LABC Section 2321.6 for wood-to-wood anchorage.

**2.7** The anchorage of concrete or masonry structural walls to wood diaphragms shall comply with LABC Section 1613.5.3. The use as flexible horizontal diaphragm to rigid wall anchor connectors is outside the scope of this supplement.

**2.8** This supplement expires concurrently with ER-200.

For additional information about this evaluation report please visit [www.uniform-es.org](http://www.uniform-es.org) or email us at [info@uniform-es.org](mailto:info@uniform-es.org)