



Report Number: 0143
Issued: 06/2009
Expires: 06/2010
Revised 09/28/2009

DIVISION: 06—WOOD AND PLASTICS
Section: 06090—Wood and Plastics Fastenings

REPORT HOLDER:
SIMPSON STRONG-TIE COMPANY, INC.
5956 WEST LAS POSITAS BOULEVARD
PLEASANTON, CALIFORNIA 94588
(800) 925-5099
www.strongtie.com

EVALUATION SUBJECT:

SIMPSON STRONG-TIE BOLT HOLD-DOWNS

1.0 EVALUATION SCOPE

1.1 Compliance with the following codes:

- 2006 International Building Code® (IBC)
- 2006 International Residential Code® (IRC)

1.2 Evaluated in accordance with:

- ICC-ES AC155, Acceptance Criteria for Hold-Downs attached to wood members, editorially revised April 2008

Property evaluated:

- Structural

2.0 USES

Simpson Strong-Tie structural bolt hold-down connectors are used as wood framing anchorage, to connect wood posts to concrete foundations or to connect an upper-story wood post to a lower-story supporting wood post, in accordance with IBC Sections 2304.9.3, 2305.1, 2305.3.2, 2305.3.7, 2305.3.8.2.4, and 2308.9.3.1. As required by IBC Section 1604.8, the hold-down connectors are used as anchorage of concrete and masonry walls to structural wood elements to provide lateral support for the walls.

When regulated under the IRC, the hold-down connectors may also be used when an engineered design is submitted in accordance with Section R301.1.3 of the IRC, or in alternate braced wall panels per IRC Sections R602.10.6.1 or R602.10.6.2.

3.0 DESCRIPTION

3.1 Product Information:

3.1.1 HDA Bolt Hold-down: The HDA bolt hold-down consist of a steel strap with bolt holes used to connect the hold-down to the wood member. The lowest bolt in the wood member is seven-bolt diameters from the end of the wood member, designed to obtain full load value, if the hold-down is placed flush onto the sill plate. The HDA has a load transfer plate, installed in the seat element. This eliminates the need for an anchor bolt washer. It is die-formed from No. 12 gage galvanized steel and the base plate component is manufactured from No. 7 gage galvanized steel. See Figure 1, Table 1, and Table 2 for product dimensions, required fasteners and allowable loads.

3.1.2 HD Bolt Hold-downs: The HD bolt hold-downs consist of a main structural steel component with pre-punched holes along their side for installation of bolts used to connect the hold-down to the wood member. They have a factory welded load transfer plate at the base with a pre-punched hole for an anchor rod or bolt. The HD5 and HD7 are required to be installed raised off the sill plate to ensure the lowest bolt in the wood member is seven bolt diameters from the end of the wood member to obtain full load value. Whereas, the HD9, HD12, and HD19 hold-downs have a tapered leg that extends below the base and that positions the first bolt in the wood member seven bolt diameters from the end of the wood member. The HD5 body is die-formed from No. 7 gage steel. The HD7, HD9, HD12 and HD19 bodies are formed from No. 3 gage steel. The base plate component is manufactured from No. 3 gage steel for the HD5, $\frac{5}{16}$ inch thick for the HD7 and $\frac{3}{8}$ inch thick for the HD9, HD12, and



Report Number: 0143
 Issued: 06/2009
 Expires: 06/2010
 Revised: 09/28/2009

HD19. See Figure 1, Table 1, and Table 2 for product dimensions, required fasteners and allowable loads.

3.2 Materials:

3.2.1 Steel: The HDA hold-downs described in this report are manufactured from ASTM A 653, SS, Grade 33 galvanized steel having a minimum yield strength, F_y , of 33,000 psi (227 MPa) and a minimum ultimate tensile strength, F_u , of 45,000 psi (310 MPa). The HD hold-downs body and HD5 base plate are fabricated from ASTM A 1011, SS, Grade 33 steel having a minimum yield strength of 33,000 psi (227 MPa) and a minimum ultimate strength of 52,000 psi (359 MPa). The HD7, HD9, HD12, and HD19 base plates are manufactured from ASTM A36 steel having a minimum yield strength of 36,000 psi (248 MPa) and a minimum ultimate strength of 58,000 psi (400 MPa). Base metal thicknesses for the bolt hold-downs in this report are as follows:

GAGE	BASE METAL THICKNESS (in.)
3/8 inch	0.3600
5/16 inch	0.2975
No. 3	0.2285
No. 7 (A 1011)	0.1705
No. 7 (A 653)	0.1715
No. 12	0.0975

For SI: 1 inch = 25.4 mm

The HDA hold-downs have a minimum G90 zinc coating specification per ASTM A653. Some models may also be available with either a G185 zinc coating (indicated by model numbers ending in the letter Z) or with a batch hot-dipped galvanized coating with a minimum specified coating weight of 2.0 ounces of zinc per square foot of surface area (600 g/m^2), total for both sides in accordance with ASTM A123 (indicated by model numbers ending with the letters HDG). Model numbers do not list the Z or HDG ending in this report, but the information shown is applicable. The HD series bolt hold-downs have a painted finish.

The holder of this report (Simpson Strong-Tie Company) or the lumber treater should be notified for

recommendations on minimum corrosion resistance of steel connectors in contact with the specific proprietary preservative treated or fire retardant treated lumber.

3.2.2 Wood: When the hold-down are used, the wood members must be either sawn lumber or engineered lumber having a minimum specific gravity of 0.50 (minimum equivalent specific gravity of 0.50 for engineered lumber), and having a maximum moisture content of 19 percent (16 percent for engineered lumber). The minimum wood member thickness (depth) is specified in Table 1.

3.2.3 Fasteners:

3.2.3.1 Bolts: Machine bolts must comply with ANSI/ASME Standard B18.2.1 and with ASTM A307. The minimum bending yield strength, (F_{yb}), of the bolt must be 45,000 psi (310 MPa).

3.2.3.2 Threaded Anchor Rods: As a minimum, threaded steel anchor rods must comply with ASTM A36 or ASTM F1554, Grade 36.

3.2.3.3 Preservative-treated and fire-retardant-treated wood: Fasteners used in contact with preservative-treated or fire-retardant-treated lumber must comply with IBC Section 2304.9.5 or IRC Section R319.3, as applicable. The report holder or lumber treater should be notified for recommendations on minimum corrosion resistance and connection capacities of fasteners used with the specific proprietary preservative-treated or fire-retardant treated lumber.

4.0 DESIGN AND INSTALLATION

4.1 Design:

4.1.1 Hold-Down Assembly: As shown in Table 1 of this report, the allowable loads are for hold-down assemblies consisting of the following components: (1) hold-down device; (2) an anchor bolt/rod attached to the seat of the device; (3) a wood member, having minimum specified dimensions and properties; (4) quantity and size of fasteners used to attach the hold-down device to the wood member; and, in one case as noted, (5) a standard cut washer (Type A plain steel washer (W)) with dimensions conforming to ASME B18.22.1. As shown in the product tables of this report, the allowable loads are



Report Number: 0143
Issued: 06/2009
Expires: 06/2010
Revised 09/28/2009

based on allowable stress design (ASD). It includes the load duration factor, C_D , corresponding with the applicable loads in accordance with the National Design Specification (NDS) for Wood Construction.

Story drifts of the structure must be determined in accordance with Section 12.8.6 of ASCE 7-05 where design load combinations include earthquake loads or effects. The deflection of a shear wall restrained from overturning by hold-downs installed in conformity with this report may be calculated using Equation 23-2 shown in Section 2305.3.2 of the IBC, or Equation 4.3-1 shown in Section 4.3.2 of ANSI/AF&PA SDPWS-2005 (Special Design Provisions for Wind and Seismic). The total deflection values, Δ_{all} and Δ_s , at ASD-level and strength-level forces, respectively, for hold-down assemblies shown in Tables 1 of this report, include all sources of hold-down device rotation and extension, and anchor rod elongation where the length of the anchor rod is a maximum of 6 inches (152 mm) for the HDA hold-down and a maximum of 8 inches (203 mm) for the HD series hold-downs. The addition of the hold-down anchor rod elongation to the total elongation (deflection) of the hold-down assembly needs to be evaluated when the actual diameter, length or ASTM steel specification of the anchor rod differs from that shown in this report.

The symbol Δ_s as used in this report refers to the symbol d_a in section 2305.3.2 of the IBC and to the symbol Δ_a in Section 4.3.2 of ANSI/AF&PA SDPWS-2005.

Tabulated allowable loads are for hold-downs connected to wood used under constantly dry interior conditions, and where sustained temperatures are 100°F (37.8°C) or less.

The allowable loads shown in Table 1 of this report must be adjusted by the wet service factor, C_m , specified in the NDS, when hold-down are fastened to wood having a moisture content greater than 19 percent (16 percent for engineered lumber), or where wet service is anticipated.

The allowable loads shown in Table 1 in this report must be adjusted by the temperature factor, C_t , specified in the NDS when hold-down are fastened to wood that will experience sustained exposure to

temperatures, exceeding 100°F (37.8°C),

The design of wood members fastened to bolt hold-down devices must consider combined stresses due to axial tension and flexural bending induced by eccentricity in the connection. Stresses shall be evaluated at the critical net section.

4.1.2 Hold-Down Devices Used as Anchorage of Structural Walls: Allowable tensile strengths and strength level displacements are detailed in Table 2 for the HDA and HD hold-down devices. The values are for the steel anchorage device independent of the bolts used to attach the hold-down to the wood member and anchor rod. The values are also used when designing structural wall anchorage in accordance with Section 12.11.2.2.2 of ASCE 7-05.

4.1.3 Anchorage to Concrete or Masonry: A registered design professional, in accordance with Chapters 19 or 21 of the IBC, must determine the adequate embedment length and anchorage details, including edge and end distances as applicable, for design of anchorage to concrete and masonry structural members.

In accordance with Section 1912 of the IBC, where design load combinations include earthquake loads or effects, the design strength of anchorage to concrete must be determined, except for detached one-and two-family dwellings assigned to Seismic Design Category A, B or C, or located where the mapped short-period spectral response acceleration, S_s , is less than 0.4g.

4.2 Installation: Installation of the Simpson Strong-Tie hold-down connectors must be in accordance with the manufacturer's published installation instructions and this evaluation report. Where a conflict exists between this report and the manufacturers published installation instructions, this report shall prevail.

4.3 Special Inspection:

4.3.1 IBC: Periodic inspection is required for installation of bolt hold-downs described in this report that are designated as components of the seismic-force-resisting system for a structure in Seismic Design Category C, D, E, or F in accordance with Section 1707.3 or 1707.4, with the



Report Number: 0143
Issued: 06/2009
Expires: 06/2010
Revised 09/28/2009

exception of those structures qualifying under Section 1704.1.

4.3.2 IRC: Special inspections are not required.

5.0 CONDITIONS OF USE

The Simpson Strong-Tie bolt hold-down connectors detailed in this report comply with, or are acceptable alternatives to what is specified in those codes listed in Section 1.0 of this report subject to the following conditions:

5.1 The hold-downs must be manufactured, identified and installed in concurrence with the manufacturer's published installation instructions and this report. During installation, a copy of the instructions must be available at the jobsite at all times.

5.2 Calculations must be submitted to the code official showing compliance with this report. A registered design professional must prepare the calculations where required by the statutes of the jurisdiction in which the project is to be constructed.

5.3 Adjustment factors must be considered, where applicable, as noted in Section 4.1 and the applicable codes.

5.4 Connected wood members and fasteners must comply, respectively, with Sections 3.2.2 and 3.2.3 of this report.

5.5 Use of hold-down connectors with fire-retardant-treated or preservative-treated lumber must be in accordance with Section 3.2.1 of this report. Use of fasteners with fire-retardant-treated or preservative-treated lumber must be in accordance with Section 3.2.3.3 of this report.

5.6 Anchorage to masonry structural members or concrete must be designed in accordance with Section 4.1.3 of this report.

5.7 Wood member design is the responsibility of the registered design professional.

6.0 EVIDENCE SUBMITTED

Data in accordance with ICC-ES Acceptance Criteria for Hold-Downs (Tie-Downs) Attached to Wood Members (AC155), inclusive of tests and calculations. Test results are from laboratories in compliance with ISO/IEC 17025.

7.0 IDENTIFICATION

The products described in this report are identified with a die-stamped label indicating the name of the manufacturer (Simpson Strong-Tie), the model number, and the number of the index evaluation report (ER-102) which identifies products recognized in this report.



A handwritten signature in black ink, appearing to read "Dennis Hill".

Director of Evaluation Services

EVALUATION REPORT



Report Number: 0143
 Issued: 06/2009
 Expires: 06/2010
 Revised: 09/28/2009

TABLE 1 — ALLOWABLE TENSION LOADS AND DISPLACEMENTS FOR HDA AND HD BOLT HOLD-DOWN ASSEMBLIES^{1,2,3,4}

MODEL NO.	DIMENSIONS (in.)							FASTENERS			MINIMUM WOOD MEMBER THK ¹¹ (in.)	ALLOWABLE TENSION LOADS ⁵ , P _{all} (lbs) C _D =1.6	DISPLACEMENT ^{6,7} Δ, (in.)	
	HB ¹⁰	SB	W	H	B	SO	CL	ANCHOR BOLT DIA. (in.)	WOOD MBR BOLTS ⁹				Δ _{all}	Δ _s
									QTY.	DIA. (in.)				
HD2A	4 ⁹ / ₁₆	2½	2¼	8	2 ⁹ / ₁₆	¾	1 ⁷ / ₁₆	¾	2	¾	1½	1,900	0.142	0.195
											2½	2,230	0.146	0.207
											3	2,230	0.158	0.223
											3½	2,230	0.151	0.219
HD5	5¼	3	2¾	6¾	3½	3¾	2½	¾	2	¾	1½	2,405	0.153	0.198
											2½	3,835	0.153	0.197
											3	4,055	0.178	0.250
											3½	4,875	0.157	0.250
											4½	5,010	0.159	0.234
HD7	6¾	3½	3½	11¼	3¾	2¾	2½	1½	3	¾	3	6,600	0.151	0.200
											3½	6,600	0.098	0.149
											4½	6,600	0.103	0.144
											5½	6,600	0.112	0.157
HD9	7	4	3½	16½	4 ⁷ / ₁₆	3¾	2½	1½	3	1	3	8,810	0.159	0.192
											3½	10,330	0.143	0.179
											4½	12,185	0.154	0.215
											5½	12,185	0.108	0.162
HD12	7	4	3½	20 ⁵ / ₁₆	4 ⁷ / ₁₆	3¾	2½	1½	4	1	3½	11,775	0.171	0.244
											4½	13,335	0.177	0.250
											5½	14,295	0.184	0.250
											4½ ¹²	14,475	0.192	0.250
											7¼	15,435	0.194	0.250
5½ ¹²	15,510	0.162	0.227											
HD19 ⁸	7	4	3½	24½	4 ⁷ / ₁₆	3¾	2½	1½	5	1	7¼	16,735	0.191	0.250
								5½ ¹²			16,775	0.200	0.250	
								7¼			19,360	0.180	0.249	
								5½ ¹²			18,550	0.133	0.198	
								5½ ¹³			19,070	0.137	0.207	

SI: 1 inch = 25.4 mm, 1 lbs = 4.45 N.

1. Tabulated allowable loads are for a hold-down assembly consisting of the hold-down device attached to a wood structural member(s) with the fasteners as specified in Table 1.
2. The allowable loads for the hold-down assemblies are established on the allowable stress design (ASD) and include the load duration factor, C_D = 1.6, corresponding with wind/earthquake loading in accordance with the NDS. No further increase is allowed. Reduce where other load durations govern.
3. The tabulated allowable loads for the hold-down assembly must not be increased for wind or earthquake loading, when using the basic load combinations in accordance with IBC Section 1605.3.1. The tabulated allowable loads for the hold-down assembly must not be increased by 33½ percent, nor can the alternative basic load combinations be reduced by a factor of 0.75, when using the alternative basic load combinations in IBC Section 1605.3.2 that includes wind or earthquake loads.

EVALUATION REPORT



Report Number: 0143
 Issued: 06/2009
 Expires: 06/2010
 Revised: 09/28/2009

4. Anchorage to concrete or masonry must be determined in accordance with Section 4.1.3 of this report. Anchorage to concrete or masonry walls shall be in accordance with Section 4.1.2 of this report.
5. The tabulated allowable (ASD) tension loads must be multiplied by 1.4 to obtain the strength-level resistance loads related with the tabulated Δ_s deformations.
6. Tabulated displacement values, Δ_{all} and Δ_s , for hold-down assemblies include all sources of hold-down assembly elongation, such as hold-down device extension and rotation fastener slip, and anchor rod elongation, at ASD-level and strength level forces respectively.
7. Elongation of the hold-down anchor rod must be calculated when the actual unbraced length is greater than 6 inches for the HD2A hold-down, or greater than 8 inches for the HD series hold-downs, or the ASTM steel specification of the anchor rod differs from that described in the Section 3.2.4 of this report. In lieu of calculating the elongation of the hold-down anchor rod for hold-downs raised 6" to 18" above the concrete for the HD2A and 8" to 18" for the HD series, it is permitted to add an additional anchor rod elongation of 0.01 to the tabulated hold-down deflection.
8. HD19 requires a standard cut washer, conforming to Section 4.1.1 of this report, to be installed between the anchor bolt nut and the seat of the hold-down when a 1 1/8" diameter anchor bolt is used.
9. The hold-down bolts attaching the hold-down to the wood member shall be in accordance with Section 3.2.3.1 of this report and they each shall have a minimum of a standard cut washer installed between the wood post and the nut.
10. HB is the required minimum distance from the end of the post to the center of the first post bolt hole. End distance may be increased as necessary for installation. Tension values are valid for hold-downs installed flush to, or raised off of, the sill plate provided that the minimum HB distance is maintained.
11. Wood structural member(s) shall have a minimum width of 3 1/2" and be a minimum Grade No. 2 with specific gravity of 0.50 to satisfy NDS Appendix E for tension loading, unless otherwise noted.
12. Wood structural member(s) shall have a minimum width of 5 1/2" and be a minimum Grade No. 2 with specific gravity of 0.50 to satisfy NDS Appendix E for tension loading.
13. Wood structural member(s) shall have a minimum width of 5 1/2" and be a minimum Grade No. 1 with specific gravity of 0.50 to satisfy NDS Appendix E for tension loading.
14. Shear wall panel edge fastening shall be specified by the designer. Where there are multiple shear wall end posts, stagger the fastening into each post (e.g., specified panel edge fasteners spacing at 4" o.c. would equal 8" o.c. to each post of a two end post condition). Maximum spacing shall not exceed 12" o.c.

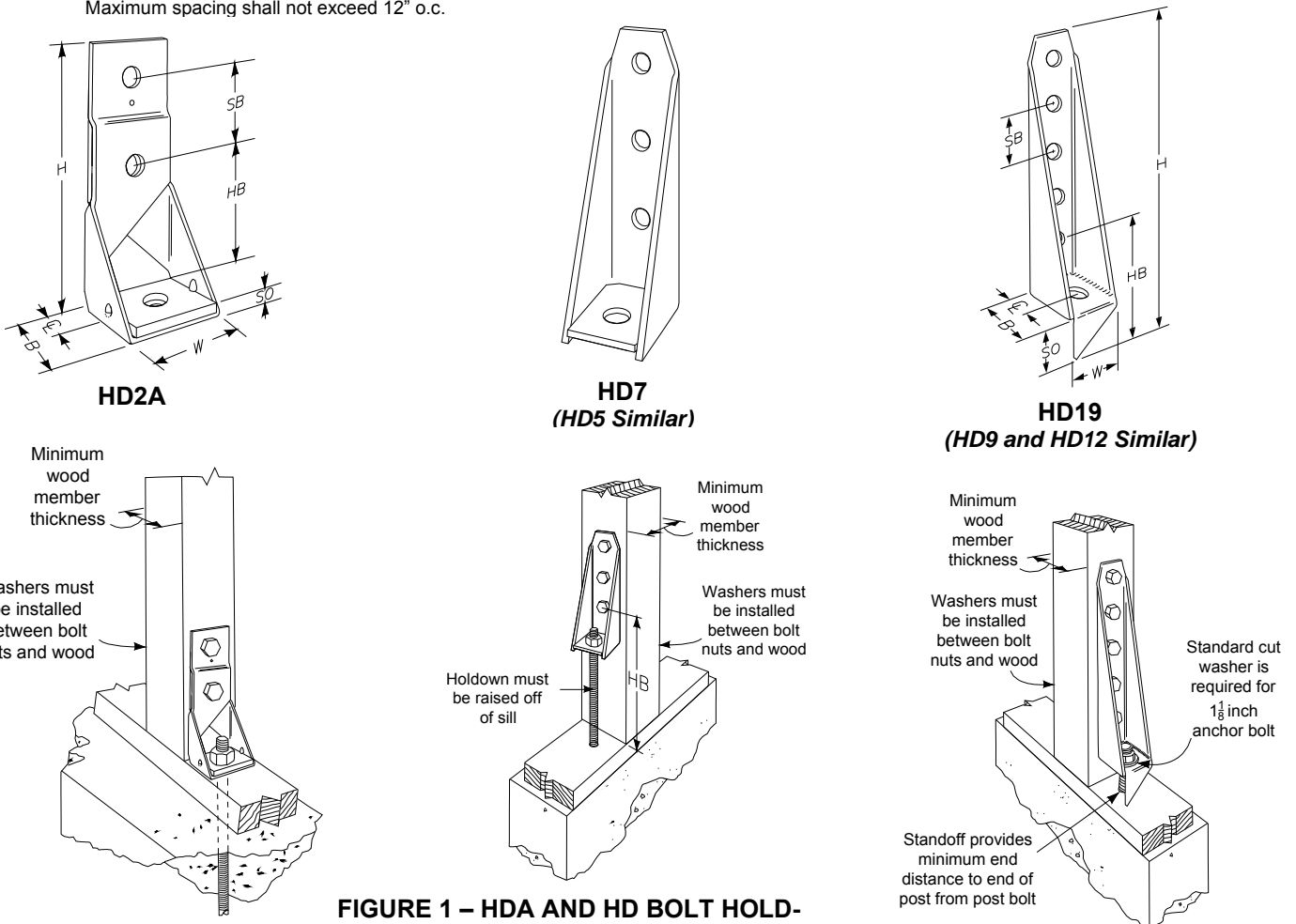

FIGURE 1 – HDA AND HD BOLT HOLD-

Report Number: 0143

Issued: 06/2009

Expires: 06/2010

Revised: 09/28/2009

HD2A Vertical Installation

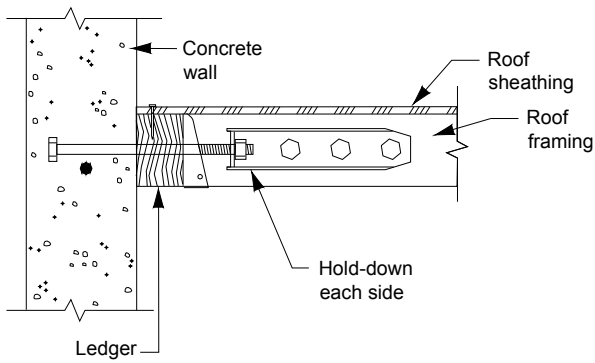

HD7 Vertical Typical Installation (HD5 Similar)

HD19 Vertical Typical Installation (HD9 and HD12 Similar)

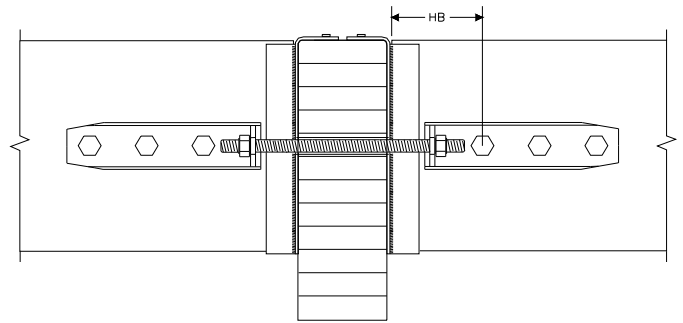

HD7 Horizontal Typical Installation (HD5 Similar)

HD7 Horizontal Purlin Installation (HD5 Similar)

FIGURE 1 – HDA AND HD BOLT HOLD-DOWNS (CON'T)



Report Number: 0143
 Issued: 06/2009
 Expires: 06/2010
 Revised: 09/28/2009

**TABLE 2 — ALLOWABLE TENSION LOADS AND DISPLACEMENTS FOR
 HDA AND HD BOLT HOLD-DOWN CONNECTORS^{2,3}**

MODEL NO.	ALLOWABLE TENSION LOAD, P_{all} (lbs)	DISPLACEMENT ⁴ , Δ (in.)	
		Δ_{all}	Δ_s
HD2A	2,230	0.137	0.185
HD5	5,735	0.074	0.185
HD7	6,600	0.045	0.071
HD9	12,185	0.052	0.069
HD12	15,510	0.064	0.094
HD19 ⁴ (1 $\frac{1}{8}$ " A.B)	21,965	0.041	0.056
HD19 (1 $\frac{1}{4}$ " A.B)	23,630	0.061	0.133

SI: 1 inch = 25.4 mm, 1 lbs = 4.45 N.

1. Tabulated allowable tensile strength of the steel hold-down connectors exclusive of fasteners and anchor rods when tested on a steel jig.
2. Designs complying with Section 12.11.2.2.2 of ASCE 7-05 (2006 IBC), allowable tension loads are applicable. The tabulated allowable loads for the hold-down must not be increased for wind or earthquake loading when using the basic load combinations in accordance with IBC Section 1605.3.1. The tabulated allowable loads for the hold-down must not be increase by 33 $\frac{1}{3}$ percent, nor can the alternative basic load combinations be reduced by a factor of 0.75, when using the alternative basic load combinations in IBC Section 1605.3.2 that includes wind or earthquake loads.
3. Tabulated displacement values, Δ_{all} and Δ_s , for hold-down device at ASD-level and strength level forces respectively. The tabulated allowable (ASD) tension loads must be multiplied by 1.4 to obtain the strength-level resistance loads associated with the tabulated Δ_s deformations.
4. HD19 requires a standard cut washer, conforming to Section 4.1.1 of this report, to be installed between the anchor bolt nut and the seat of the hold-down when a 1 $\frac{1}{8}$ " diameter anchor bolt is used.



SUPPLEMENT

Report Number: 0143

Issued: 06/2009

Expires: 06/2010

Revised: 09/28/2009

DIVISION: 06—WOOD AND PLASTICS
Section: 06090—Wood and Plastics Fastenings

REPORT HOLDER:
SIMPSON STRONG-TIE COMPANY, INC.
5956 WEST LAS POSITAS BOULEVARD
PLEASANTON, CALIFORNIA 94588
(800) 925-5099
www.strongtie.com

EVALUATION SUBJECT:

SIMPSON STRONG-TIE BOLT HOLD-DOWNS

This supplement is issued to indicate that the Simpson Strong-Tie structural bolt hold-down connectors, described in the master report, comply with the codes listed in Section 1.1 of this supplement when designed and installed in accordance with the master evaluation report and the amendments to the report as shown below.

1.0 EVALUATION SCOPE

1.1 Compliance with the following codes:

- 2007 Florida Building Code – Building (FBC-B), including HVHZ
- 2007 Florida Building Code – Residential (FBC-R), including HVHZ

6.0 EVIDENCE SUBMITTED

Signed and sealed test reports by Testing Engineers Inc. (shown below), along with calculations provided by Hien Nguyen, P.E., performed in accordance with the 2006 International Building Code.

Product	Test Number	Date Tested
HD2A	N294, N295, N297, P912, P913	4/23/07, 4/23/07, 4/20/07, 12/3/08, 12/3/08
HD5	P556, P557, P558, P787, P560, P618	9/24/08, 9/24/08, 10/1/08, 10/16/08, 9/29/08, 10/6/08
HD7	P782, P561, P563, P564, P623	10/1/08, 10/17/08, 9/22/08, 9/30/08, 10/6/08
HD9	P566, P567, P568, P783, P742	10/1/08, 9/19/08, 9/22/08, 10/20/08, 11/26/08

EVALUATION REPORT



Report Number: 0143
Issued: 06/2009
Expires: 06/2010
Revised: 09/28/2009

HD12	P571, P572, P573, P574, P575, P785, P786	10/2/08, 9/29/08, 9/29/08, 9/25/08, 9/30/08, 10/20/08, 10/21/08
HD19	P438, P439, P440, P748, P749	8/8/08, 9/5/08, 9/23/08, 10/24/08, 10/27/08